

Перв. примен.

Справ. №

Подп. и дата

Инв. № дубл.

Взам. инв. №

Подп. и дата

Инв. № подл.

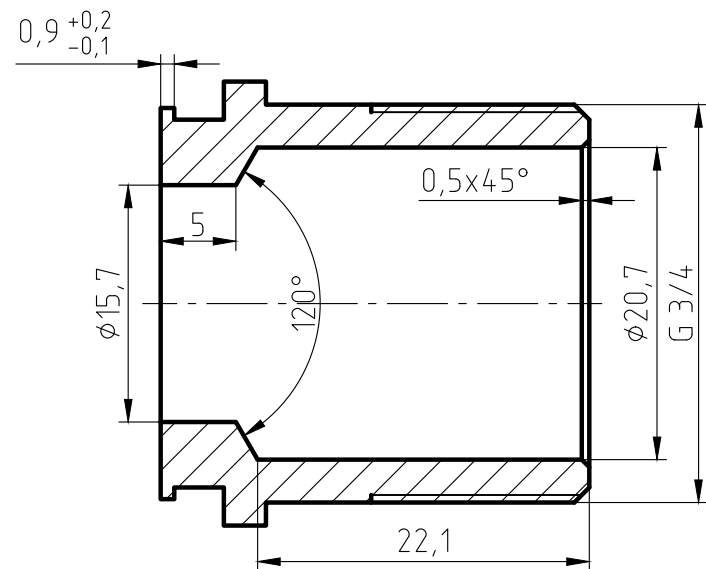
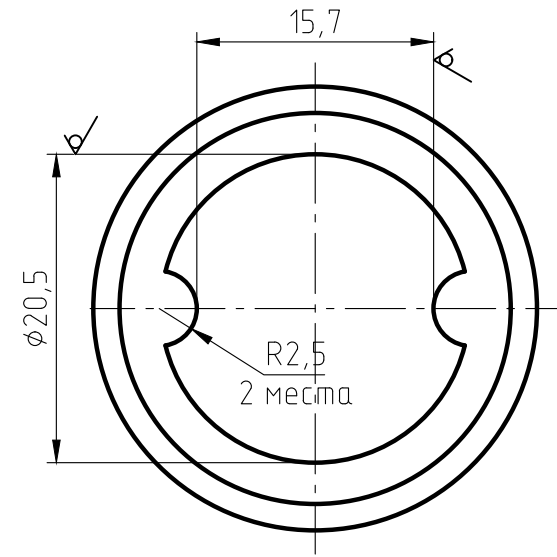
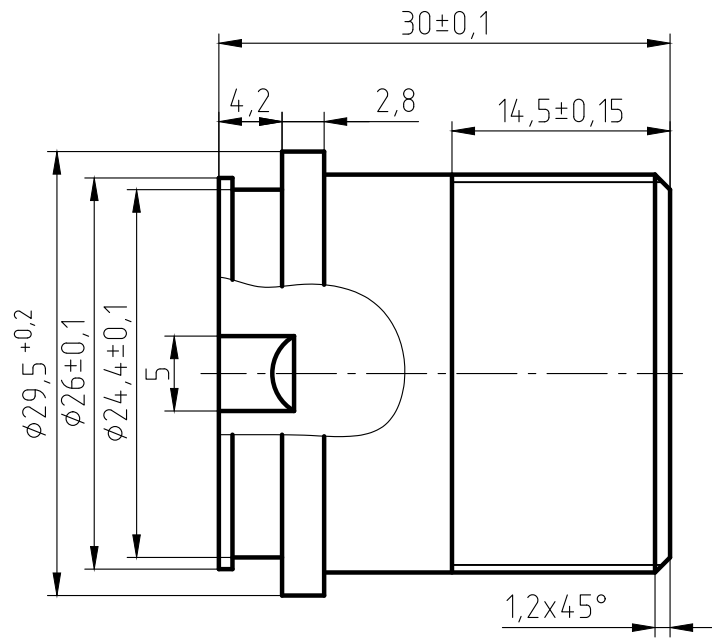

1. The parts should be 59-1 materials, no fissures surface sand-throwing treatment and nickel plating. All nickel plating.
2. Not specified R0.5, slope of 1*.
3. The logo is cave/hollow, depth is 0,3-0,5 mm.
4. Surface is clear and smoothly, deburring C0.2.
5. The dimention on the drawings are of the finished products.
6. The Male thread should be bitten.

					Штуцер американки 3/4" нн ИС.072112-1		
Изм.	Лист	№ докум.	Подп.	Дата			
Разраб.						48,5	2:1
Пров.					Лист		Листов 1
Т.контр.							
Н.контр.					ЛС 59-1 ГОСТ 15527-2004		
Утв.							