

3,2/√(✓)

Перв. примен.

Справ. №

Подп. и дата

Инв. № дубл.

Взам. инв. №

Подп. и дата

Инв. № подл.

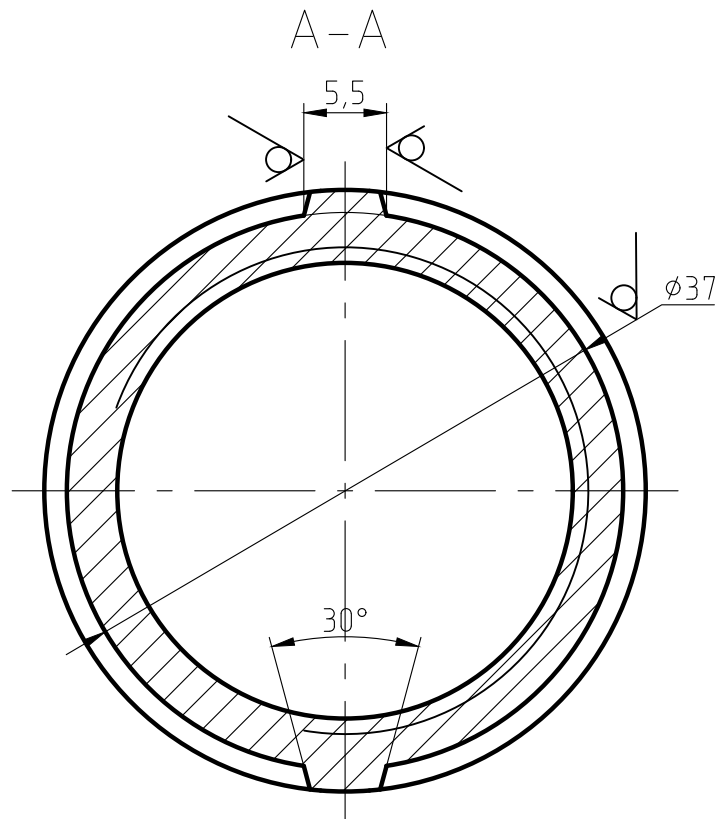
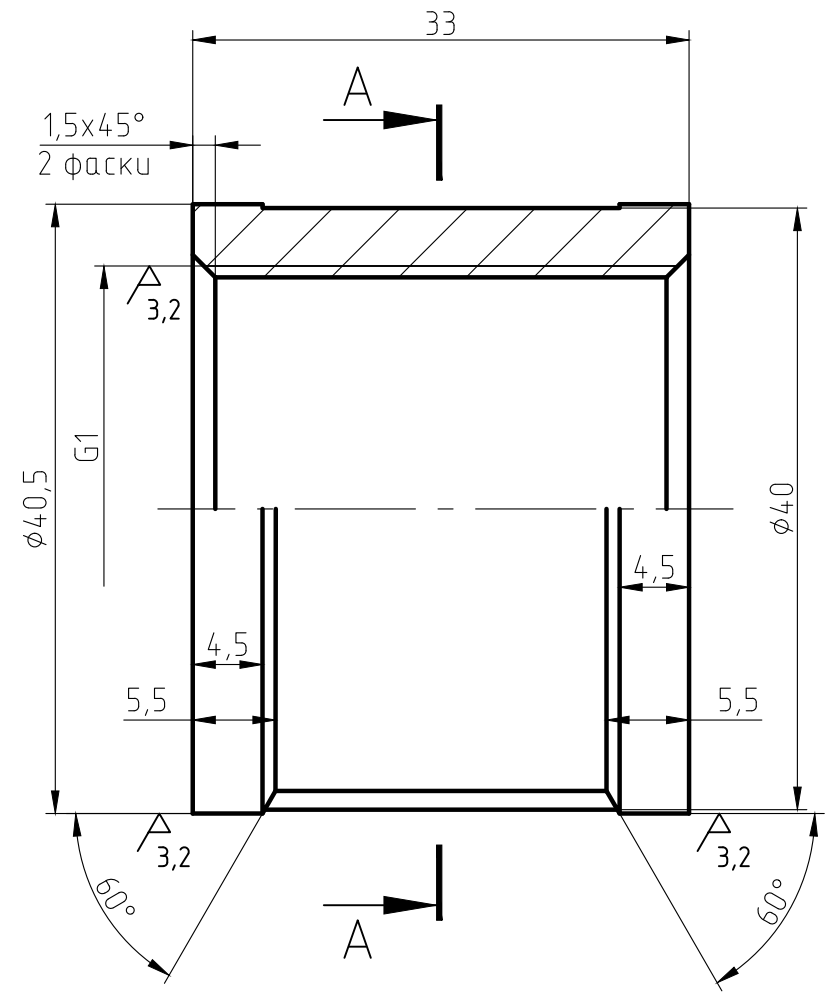

A(1:1)

127(длина окружности кольца)

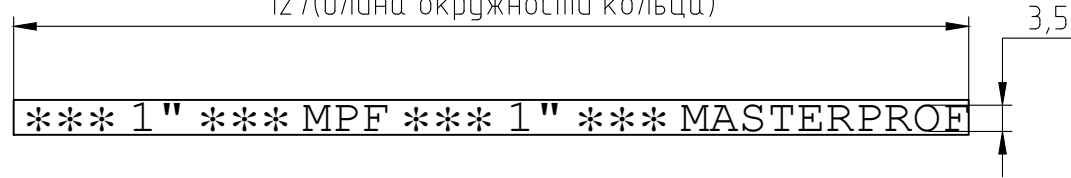

1. The parts should be 59-1 materials, no fissures surface sand-throwing treatment and nickel plating. All nickel plating.
2. Not specified R0.5, slope of 1*.
3. The logo is cave/hollow. depth is 0.3-0.5 mm.
4. Surface is clear and smoothly, deburring C0.2.
5. The dimentions on the drawings are of the finished products.
6. The Male thread should be bitten.

Изм.	Лист	№ докум.	Подп.	Дата			
Разраб.					Муфта 1" ВВ ИС.071986		
Пров.							
Т.контр.					Лист	Листов	1
Н.контр.					ЛС 59-1 ГОСТ 15527-2004		
Утв.							

Копировал

Формат А3