

3/2 (✓)

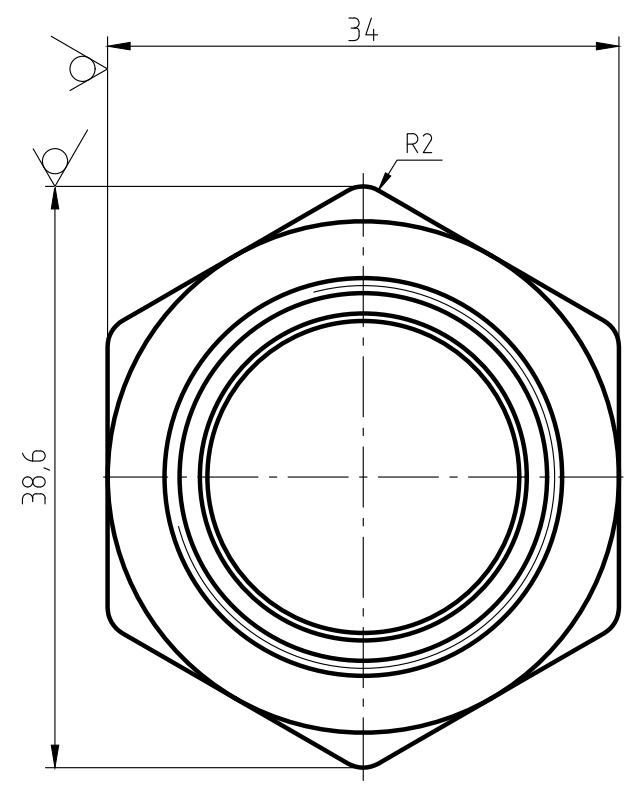
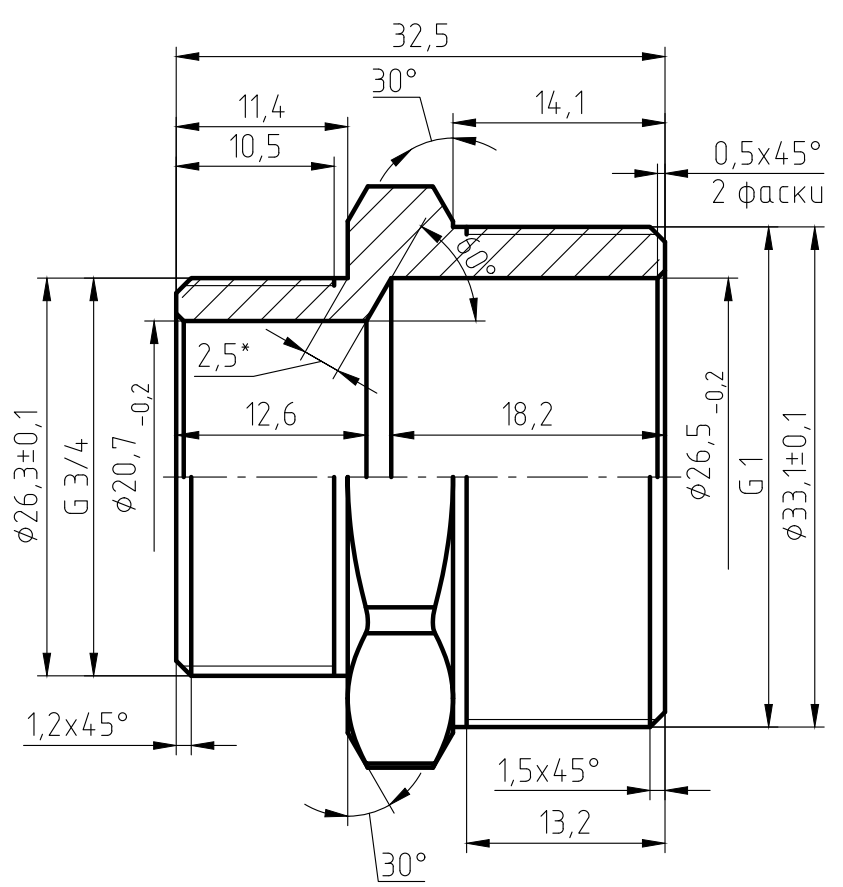

1. The parts should be 59-1 materials, no fissures surface sand-throwing treatment and nickel plating. All nickel plating.
2. Not specified R0.5, slope of 1°.
3. Surface is clear and smoothly, deburring C0.2.
4. The dimensions on the drawings are of the finished products.
5. The Male thread should be bitten.

Перв. примен.	Справ. №	Подп. и дата	Инв. № дудл.	Взам. инв. №	Подп. и дата	Инв. № подл.
---------------	----------	--------------	--------------	--------------	--------------	--------------

Изм.	Лист	№ докум.	Подп.	Дата	Ниппель переходник 3/4"-1" НН ИС.072016	Лист	Масса	Масштаб
Разраб.							73,7	2:1
Пров.						Лист	Листов	1
Т.контр.						ЛС 59-1 ГОСТ 15527-2004		
Н.контр.								
Утв.								