

√ Ra 3,2 (✓)

Перв. примен.
Справ. №

Подп. и дата
Инв. № дубл.
Взам. инв. №
Подп. и дата
Инв. № подл.

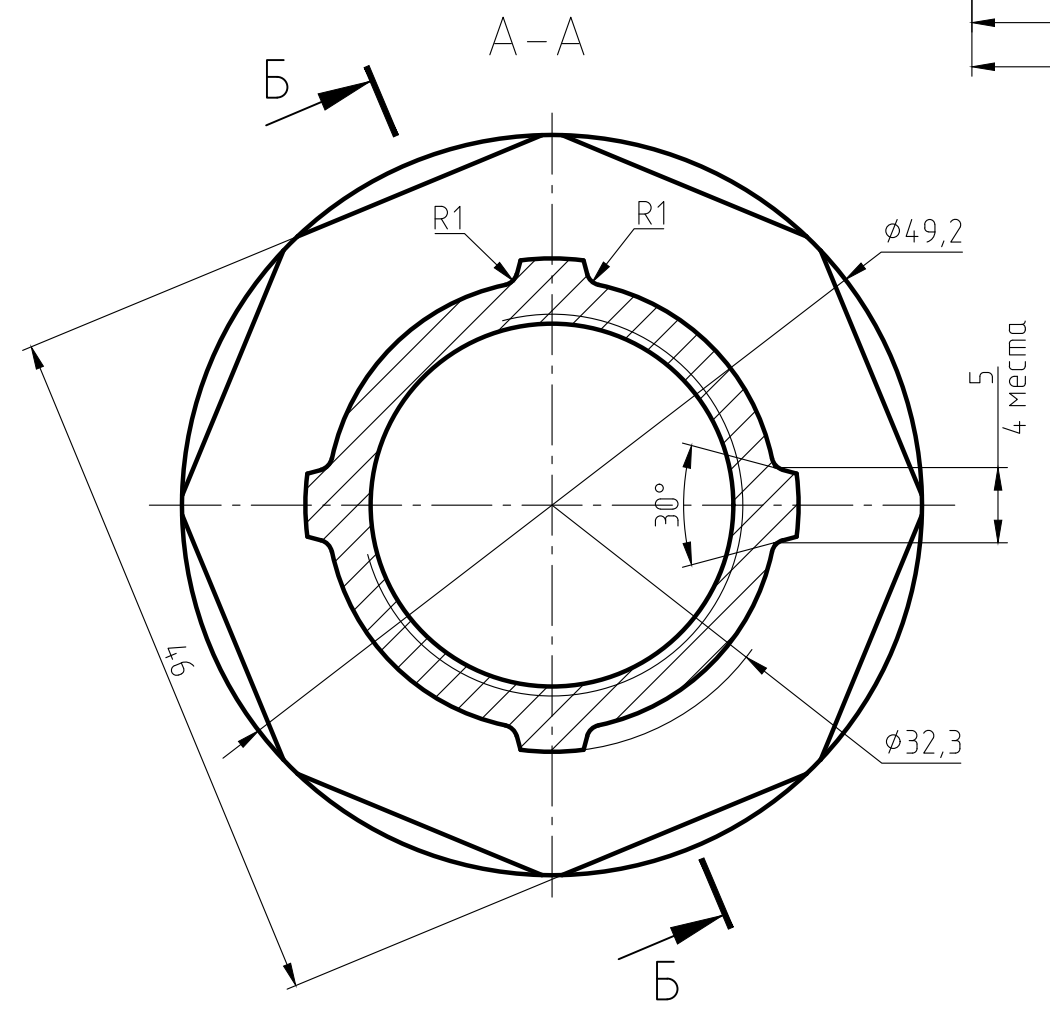
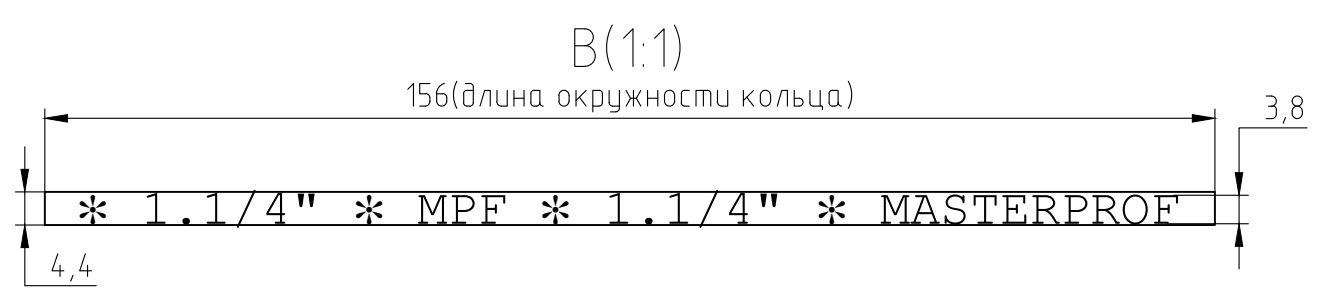
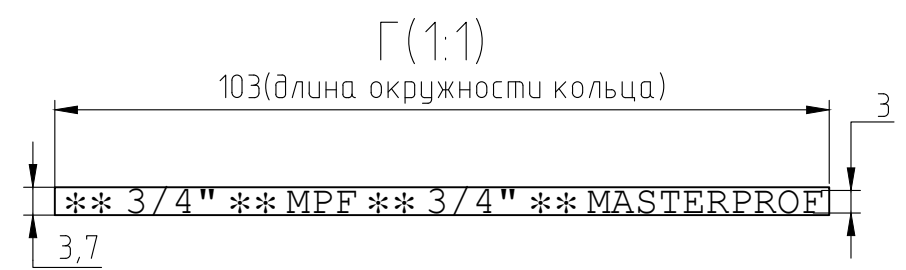
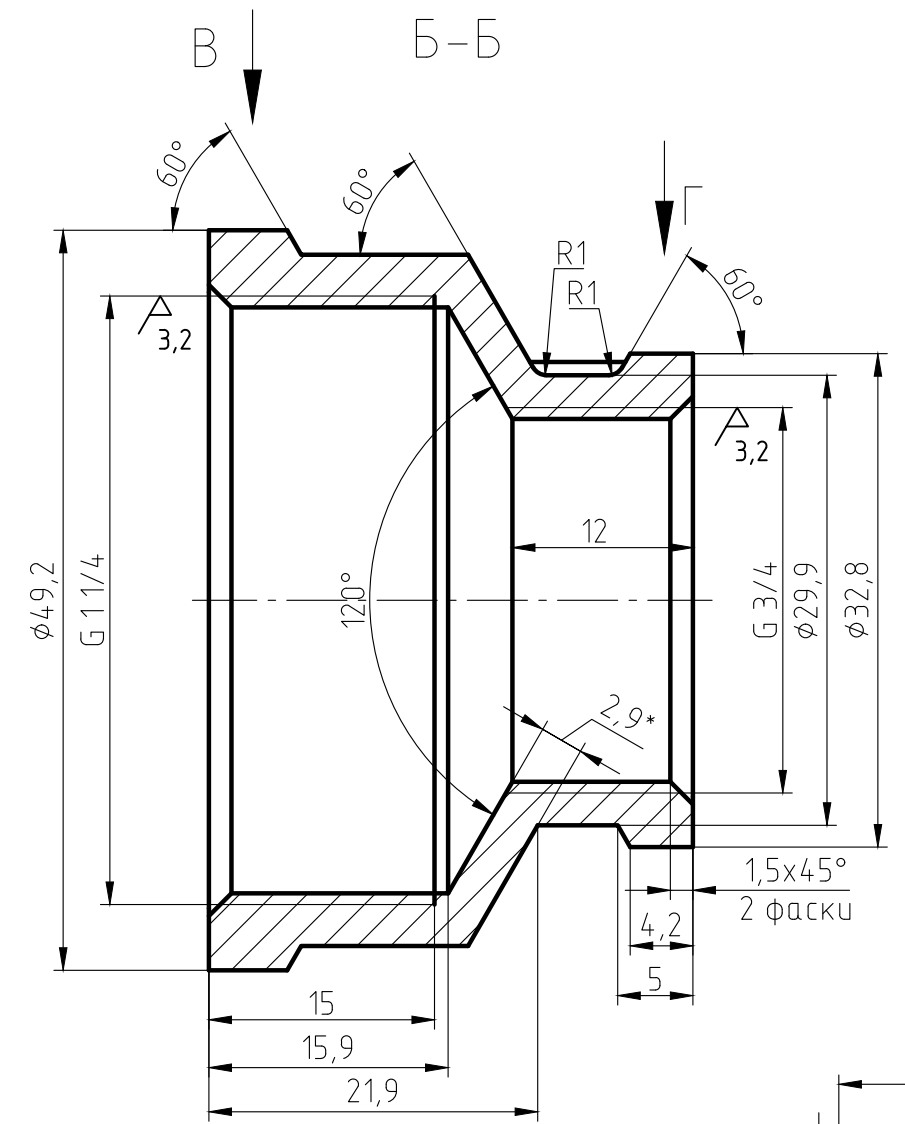
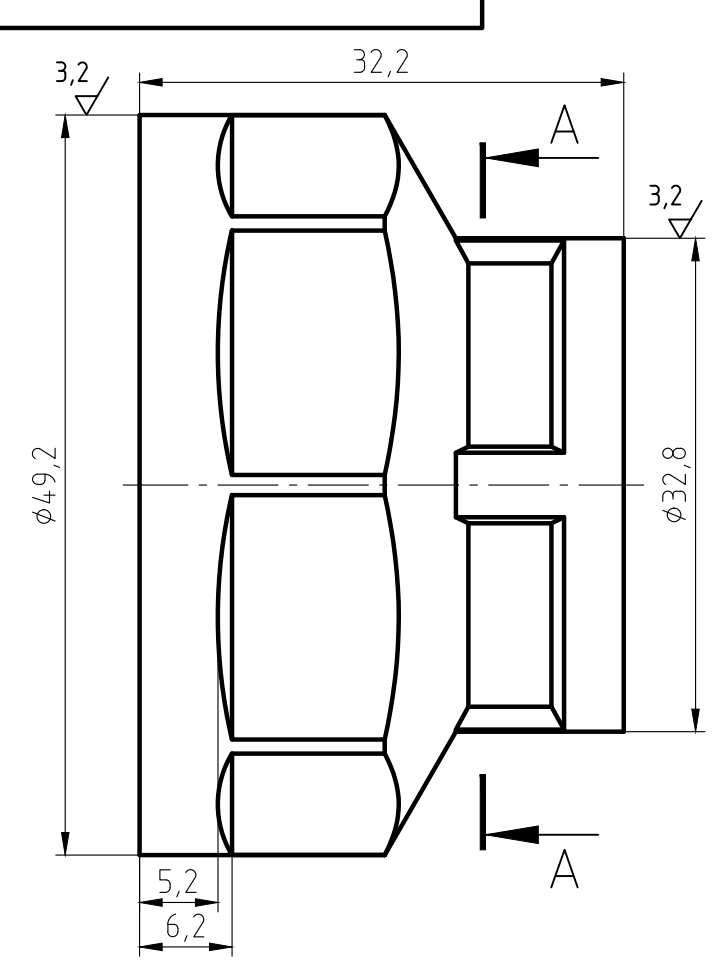

1. The parts should be 59-1 materials, no fissuress surface sand-throwing treatment and nickel plating. All nickel plating.
2. Not specified R0.5, slope of 1*.
3. The logo is cave/hollow. depth is 0.3-0.5 mm.
4. Surface is clear and smoothly, deburring C0.2.
5. The dimentions on the drawings are of the finished products.
6. The Male thread should be bitten.

Изм.	Лист	№ докум.	Подп.	Дата	Муфта переходная 1 1/4"х3/4" ВВ ИС.071995	Лист	Масса	Масштаб
Разраб.							123,4	2:1
Пров.						Лист		Листов 1
Т.контр.						ЛС 59-1 ГОСТ 15527-2004		
Н.контр.								
Утв.								