

3,2/√(✓)

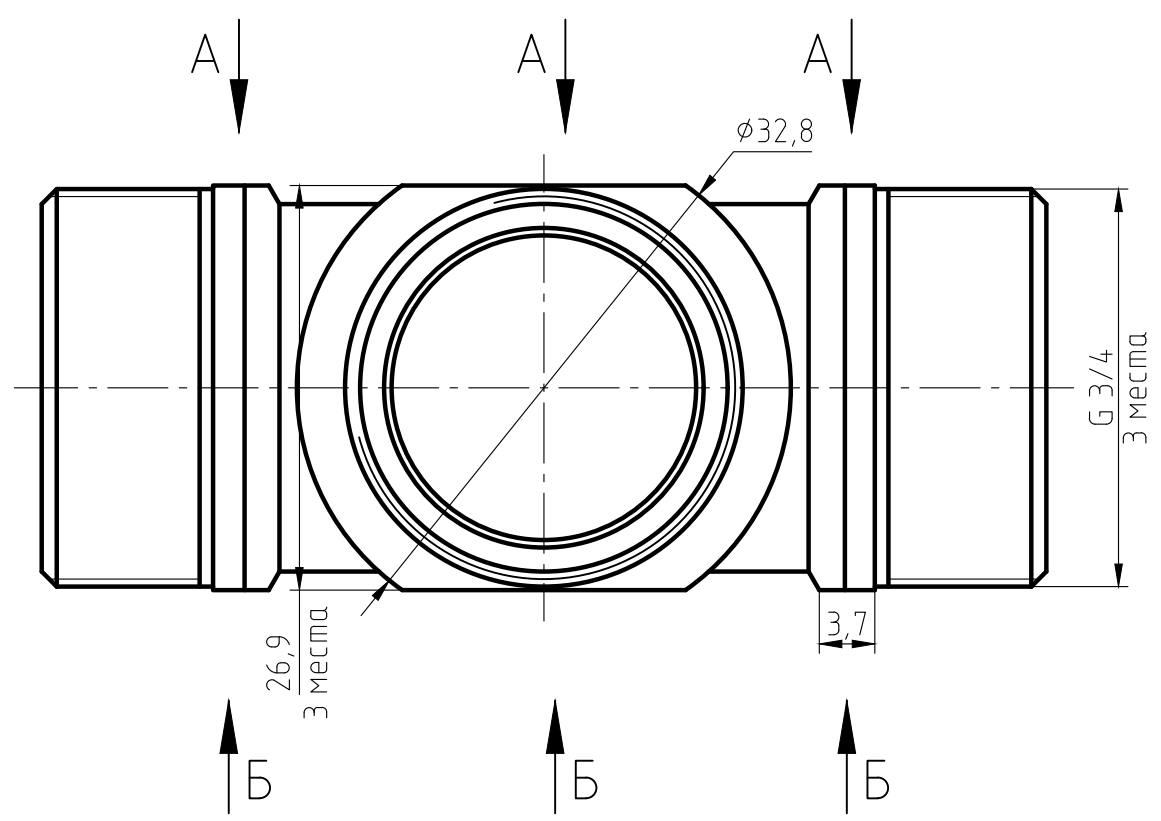
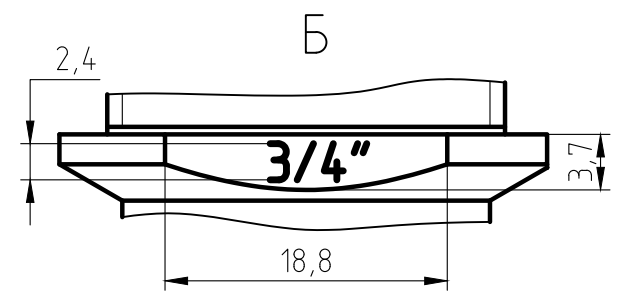
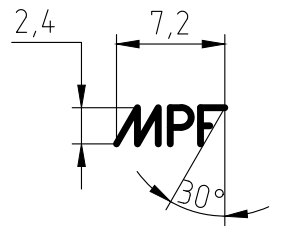
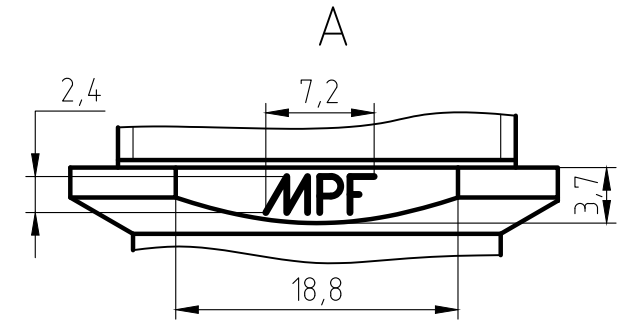
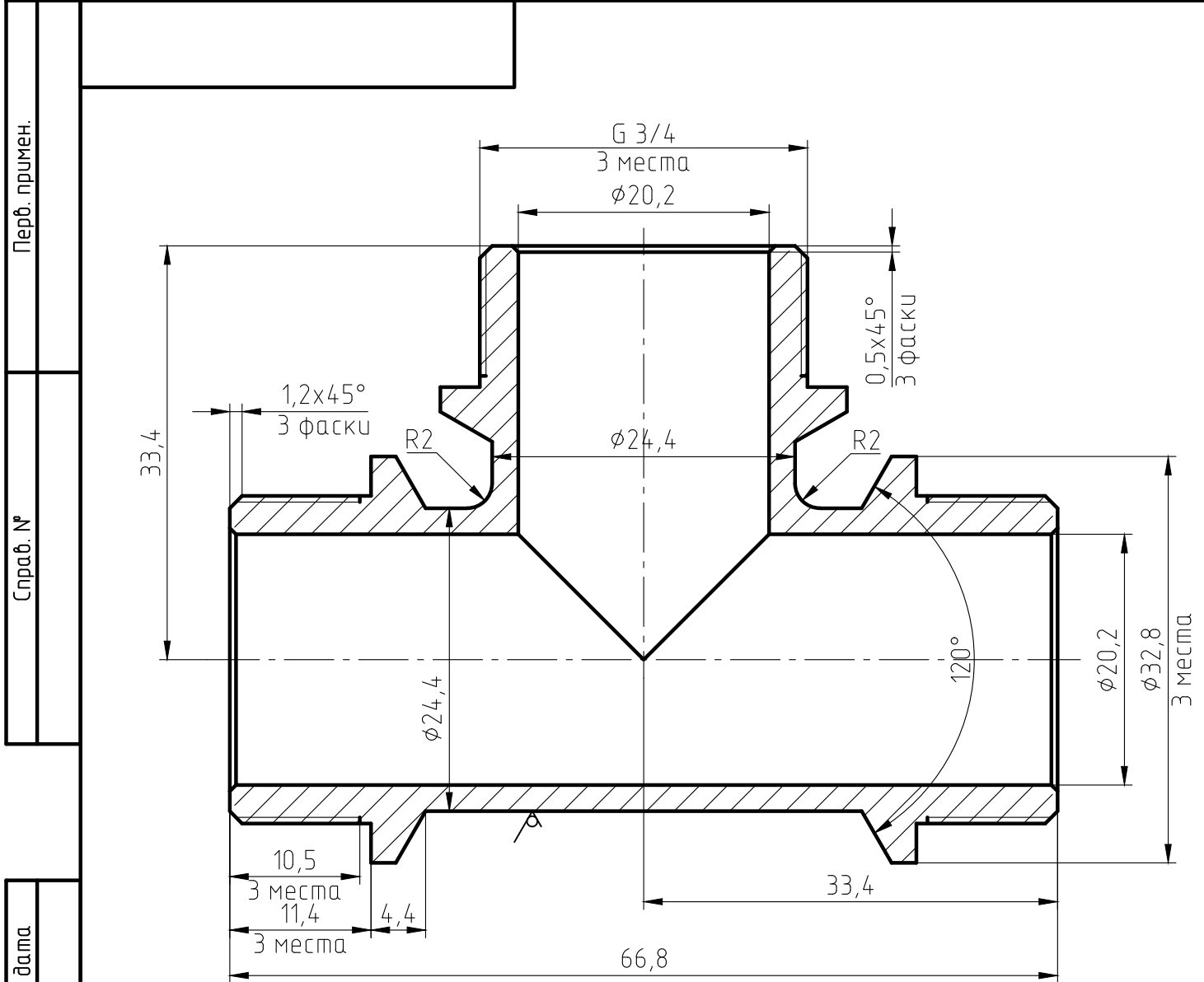

1. The parts should be 59-1 materials, no fissuress surface sand-throwing treatment and nickel plating. All nickel plating.
2. Not specified R0.5, slope of 1*.
3. The logo is cave/hollow. depth is 0.3-0.5 mm.
4. Surface is clear and smoothly, deburring C0.2.
5. The dимentions on the drawings are of the finished products.
6. The Male thread should be bitten.

Перв. примен.	
Справ. №	
Подп. и дата	
Инв. № дубл.	
Взам. инв. №	
Подп. и дата	
Инв. № подл.	

Изм.	Лист	№ докум.	Подп.	Дата	Тройник 3/4" ННН ИС.072073	Лист	Масса	Масштаб
Разраб.							141,8	2:1
Пров.						Лист	Листов	
Т.контр.								
Н.контр.					ЛС 59-1 ГОСТ 15527-2004			
Утв.								