

3,2/√(✓)

Перв. примен.

Справ. №

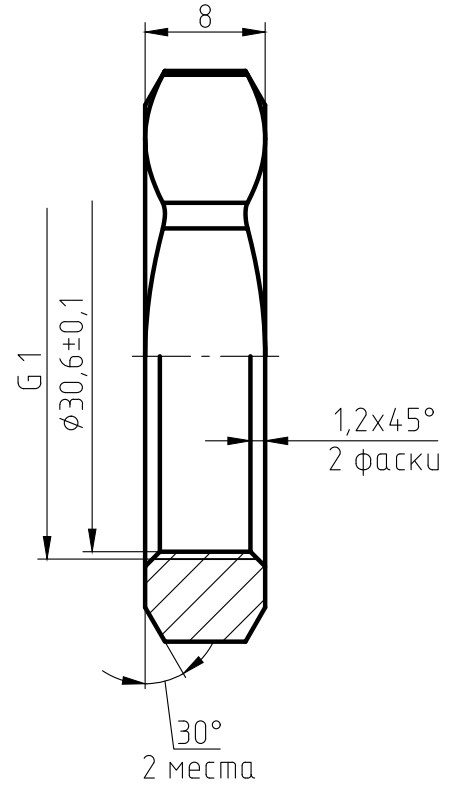
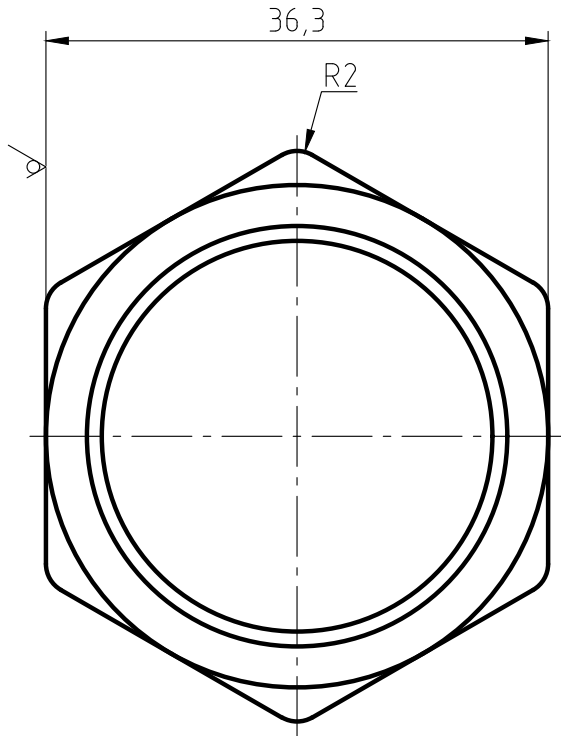

Подп. и дата

Инв. № дубл.

Взам. инв. №

Подп. и дата

Инв. № подл.

1. The parts should be 59-1 materials, no fissures surface sand-throwing treatment and nickel plating. All nickel plating.
2. Not specified R0.5, slope of 1*.
3. The logo is cave/hollow. depth is 0.3-0.5 mm.
4. Surface is clear and smoothly, deburring C0.2.
5. The dimentions on the drawings are of the finished products.
6. The Male thread should be bitten.

| Изм. | Лист | № докум. | Подп. | Дата |
|----------|------|----------|-------|------|
| Разраб. | | | | |
| Пров. | | | | |
| Т.контр. | | | | |
| Н.контр. | | | | |
| Утв. | | | | |

Контрзаїка 1"
ИС.072132

| Лист | Масса | Масштаб |
|------|--------|---------|
| | 22,6 | 2:1 |
| Лист | Листов | |

ЛС 59-1 ГОСТ 15527-2004