

3,2
▽(V)

Перв. примен.
Справ. №
Подп. и дата
Инв. № дубл.
Взам. инв. №
Подп. и дата
Инв. № подл.

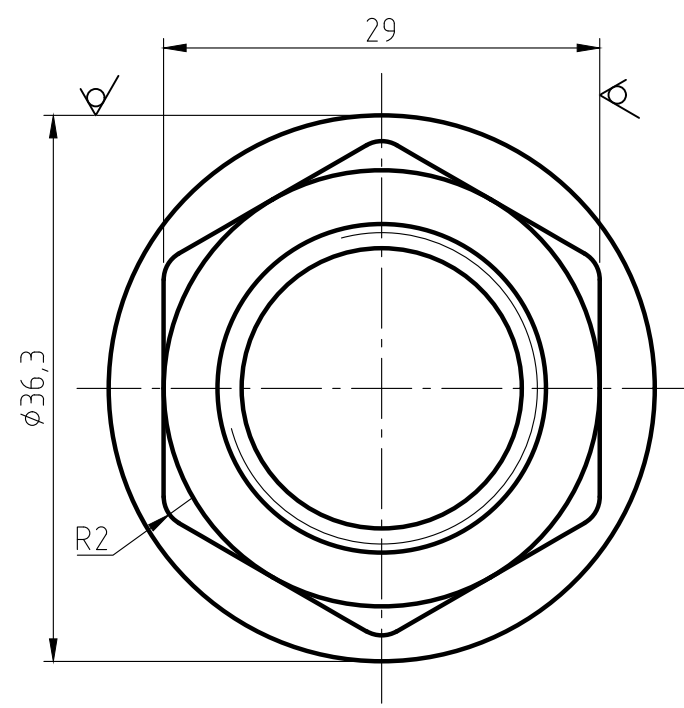
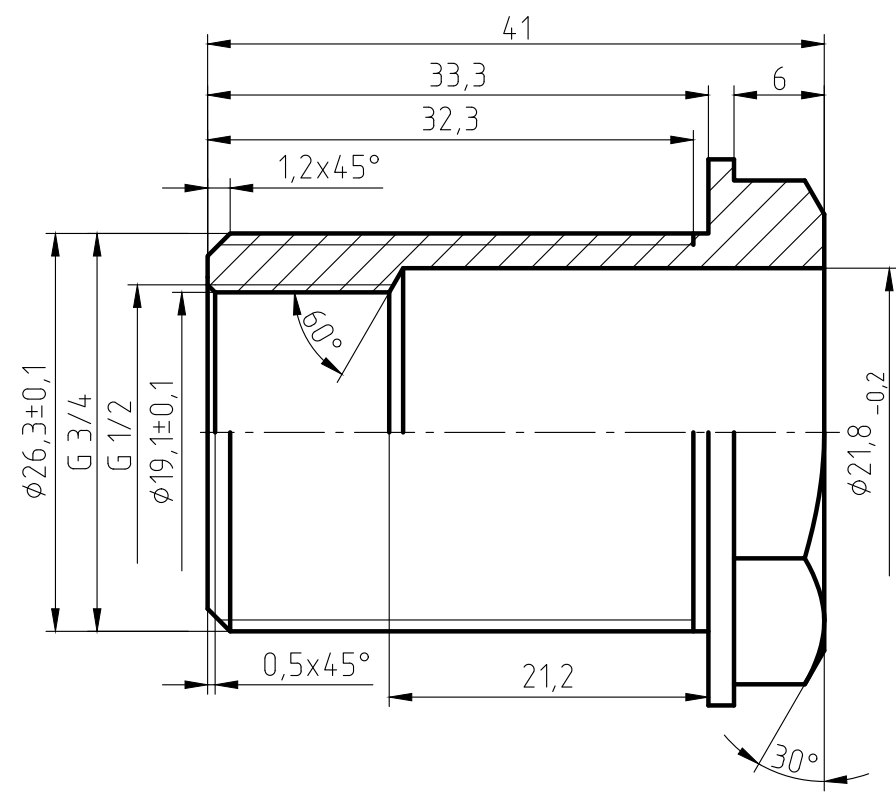

1. The parts should be 59-1 materials, no fissures surface sand-throwing treatment and nickel plating. All nickel plating.
2. Not specified R0.5, slope of 1*.
3. The logo is cave/hollow, depth is 0,3-0,5 mm.
4. Surface is clear and smoothly, deburring C0.2.
5. The dimentions on the drawings are of the finished products.
6. The Male thread should be bitten.

					Врезка в бак 3/4" штуцер ИС.071264-1	Лист	Масса	Масштаб
Изм.	Лист	№ докум.	Подп.	Дата			68,2	2:1
Разраб.						Листов 1		
Пров.								
Т.контр.								
Н.контр.								
Утв.								