

✓(✓)

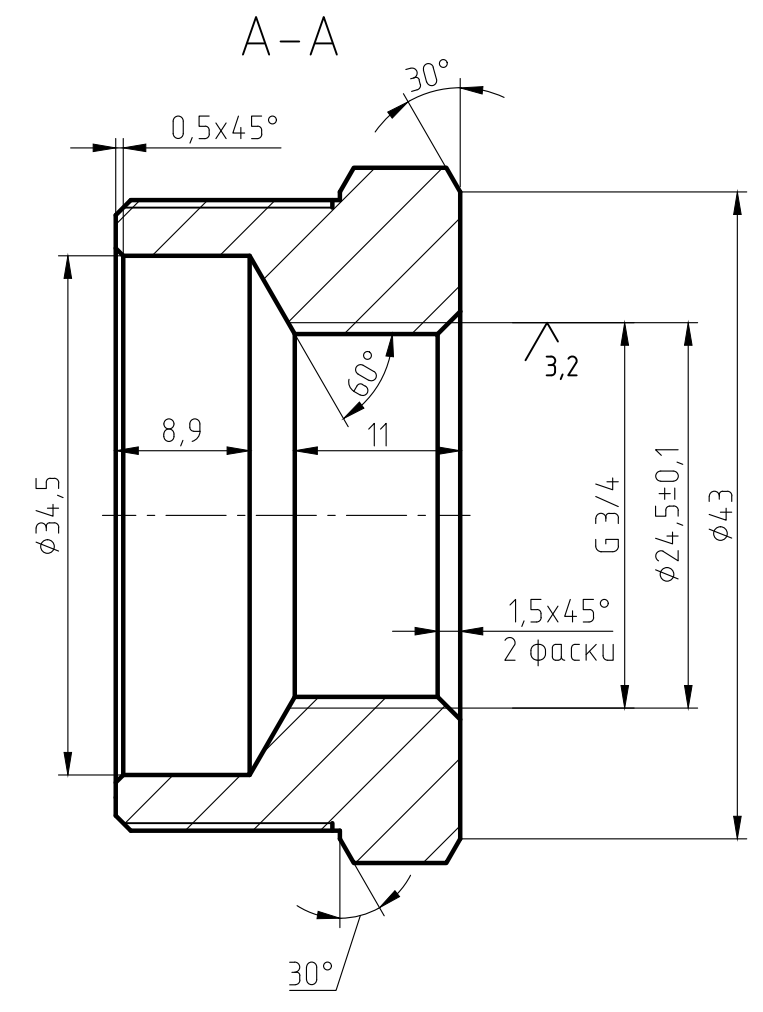
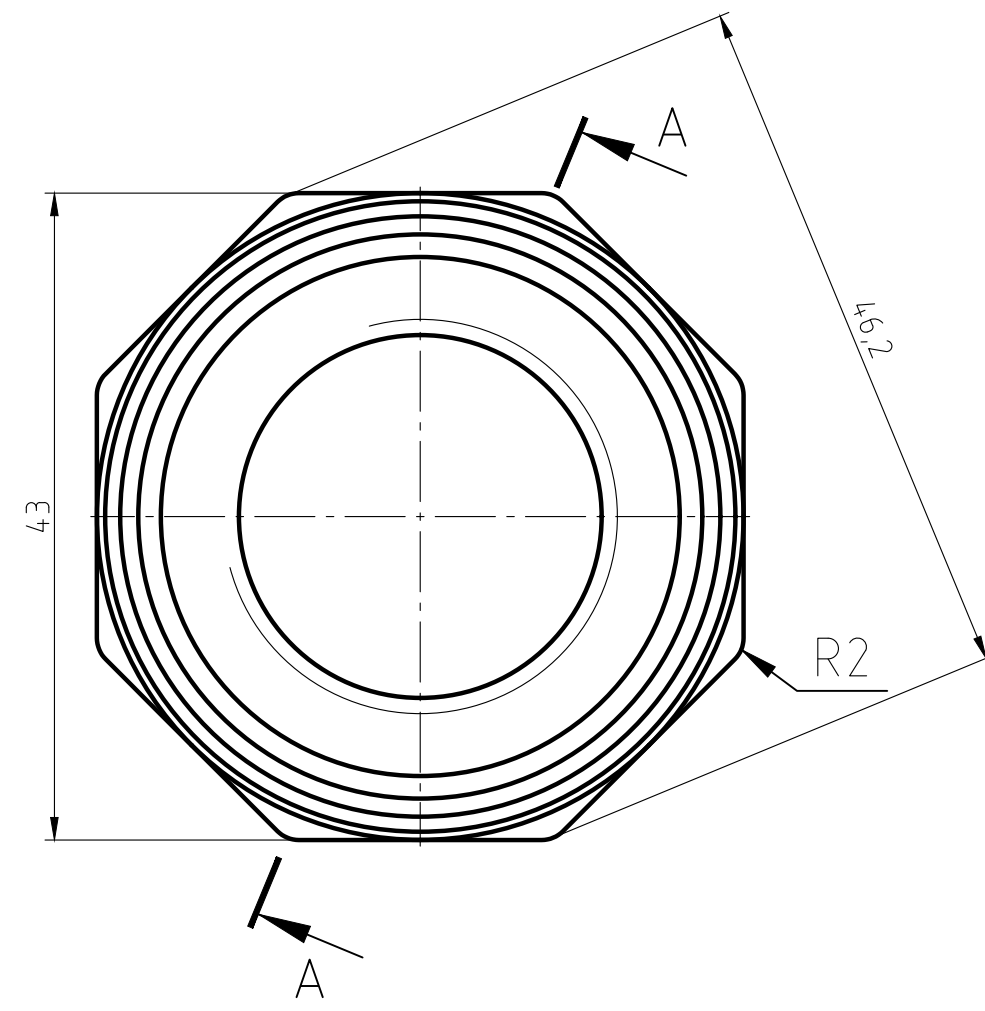
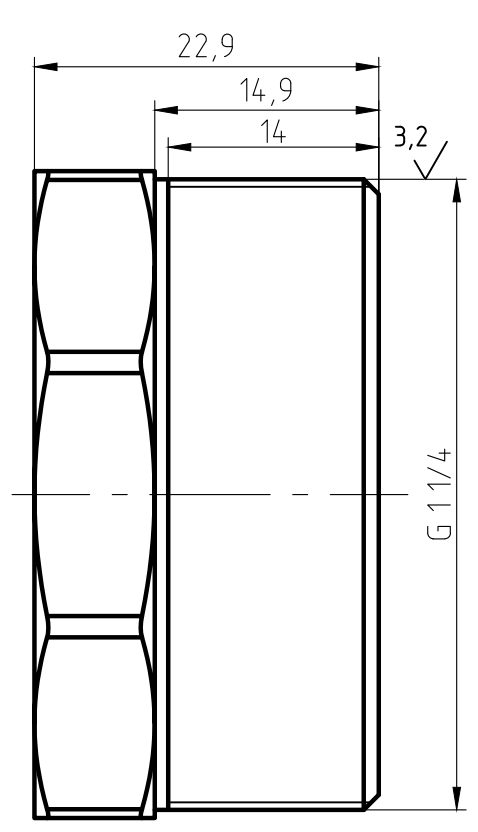

1. The parts should be 59-1 materials, no fissures surface sand-throwing treatment and nickel plating. All nickel plating.
2. Not specified R0.5, slope of 1°.
3. The logo is cave/hollow. depth is 0.3-0.5 mm.
4. Surface is clear and smoothly, deburring C0.2.
5. The dimention on the drawings are of the finished products.
6. The Male thread should be bitten.

Перв. примен.	
Справ. №	
Подп. и дата	
Инв. № дубл.	
Взам. инв. №	
Подп. и дата	
Инв. № подл.	

Изм.	Лист	№ докум.	Подп.	Дата	Фурорка 3/4"x1 1/4" НВ ИС.072049 ЛС 59-1 ГОСТ 15527-2004	Лист	Масса	Масштаб
Разраб.							129,8	2:1
Пров.						Лист	Листов	
Т.контр.								
Н.контр.								
Утв.								