

Перв. примен.

Справ. №

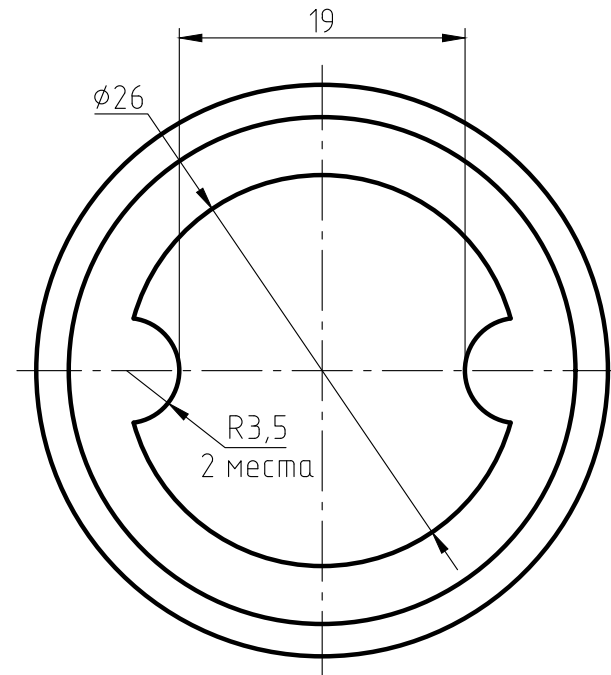
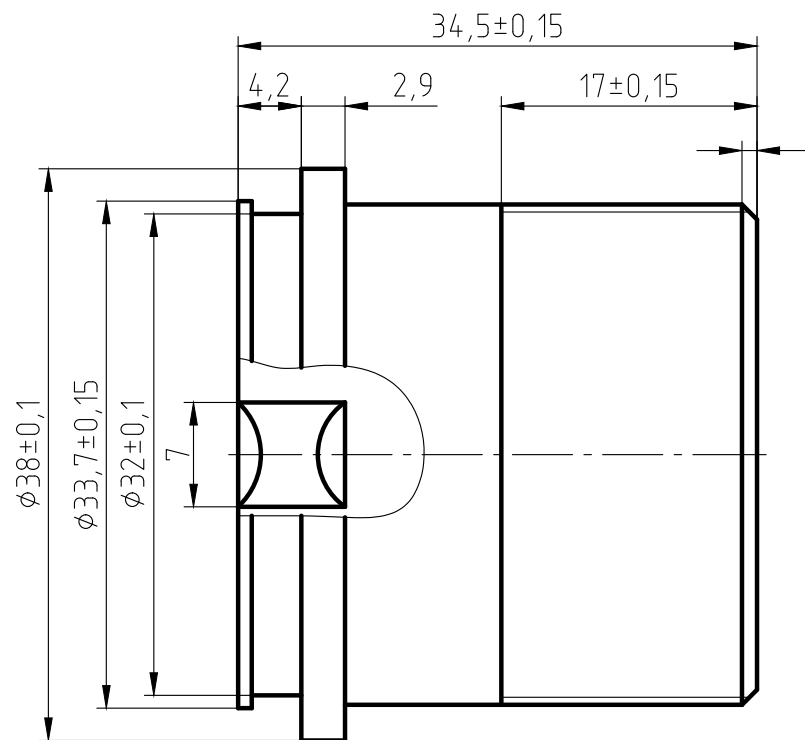

Подп. и дата

Инв. № дубл.

Взам. инв. №

Подп. и дата

Инв. № подл.

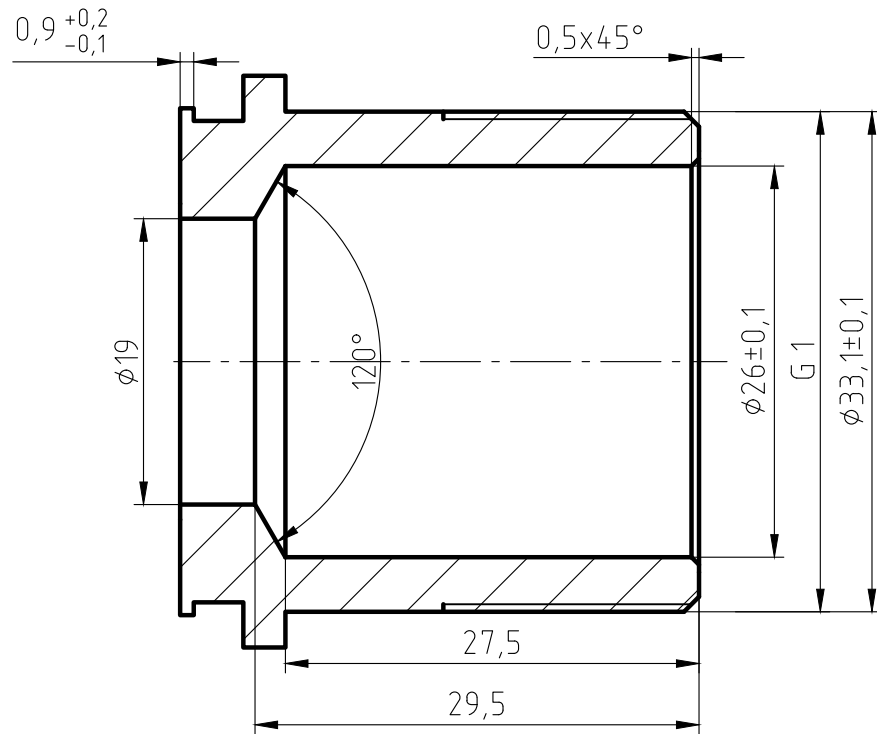

1. The parts should be 59-1 materials, no fissures surface sand-throwing treatment and nickel plating. All nickel plating.
2. Not specified R0.5, slope of 1°.
3. The logo is cave/hollow, depth is 0,3-0,5 mm.
4. Surface is clear and smoothly, deburring C0.2.
5. The dimentions on the drawings are of the finished products.
6. The Male thread should be bitten.

Изм.	Лист	№ докум.	Подп.	Дата	Штуцер американки 1" вн ИС.072107-3	Лист	Масса	Масштаб
Разраб.							91,1	2:1
Пров.						Лист	Листов	1
Т.контр.								
Н.контр.					ЛС 59-1 ГОСТ 15527-2004			
Утв.								