

3,2/√(√)

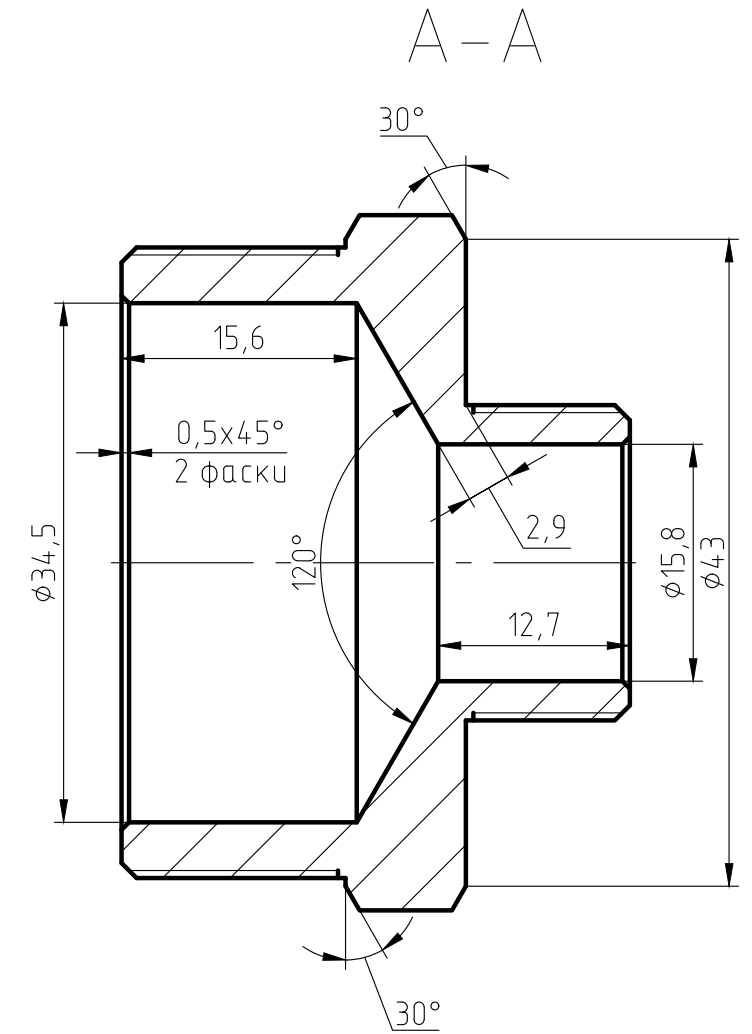
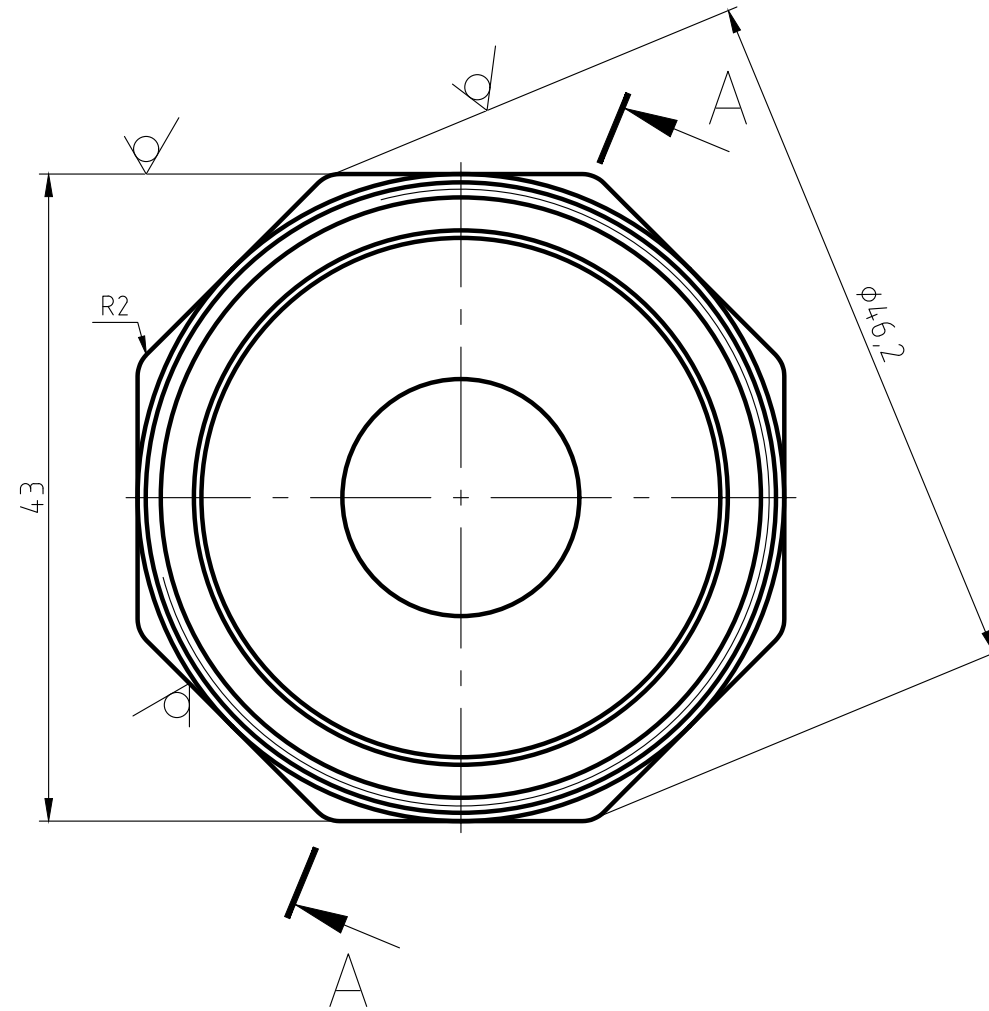
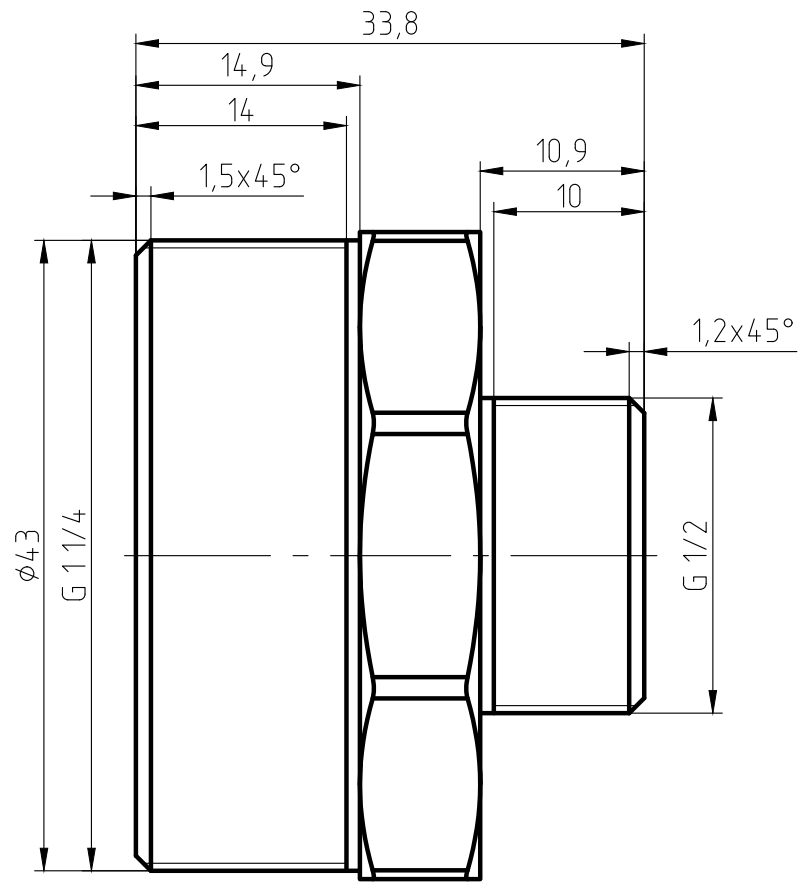

1. The parts should be 59-1 materials, no fissures surface sand-throwing treatment and nickel plating. All nickel plating.
2. Not specified R0.5, slope of 1\*.
3. Surface is clear and smoothly, deburring CO.2.
4. The dimentions on the drawings are of the finished products.
5. The Male thread should be bitten.

Перв. примен.	Справ. №
Подп. и дата	Инв. № дудл.
Подп. и дата	Взам. инв. №
Инв. № подл.	

					Ниппель переходник 1/2"-1 1/4" НН ИС.072017	Лист	Масса	Масштаб
Изм.	Лист	№ докум.	Подп.	Дата			124,3	2:1
Разраб.						Лист	Листов	1
Пров.					ЛС 59-1ГОСТ 15527-2004			
Т.контр.								
Н.контр.								
Утв.								