

3,2/√(√)

Перв. примен.

Справ. №

Подп. и дата

Инв. № дубл.

Взам. инв. №

Подп. и дата

Инв. № подл.

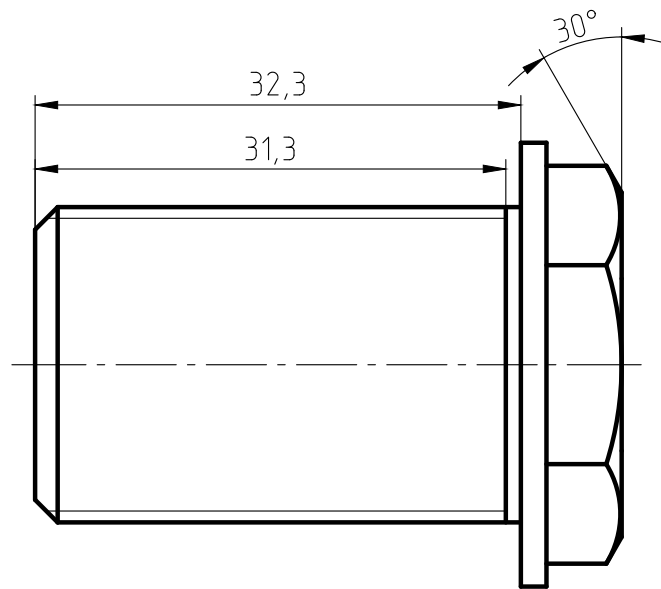
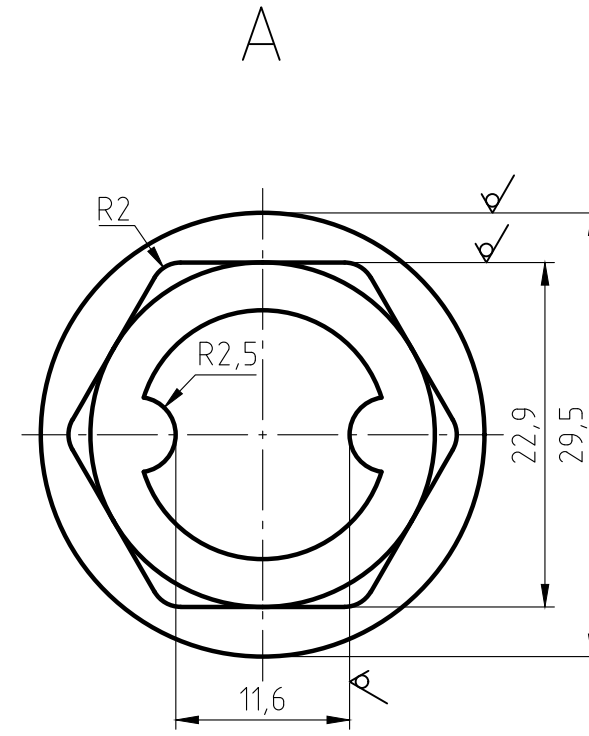
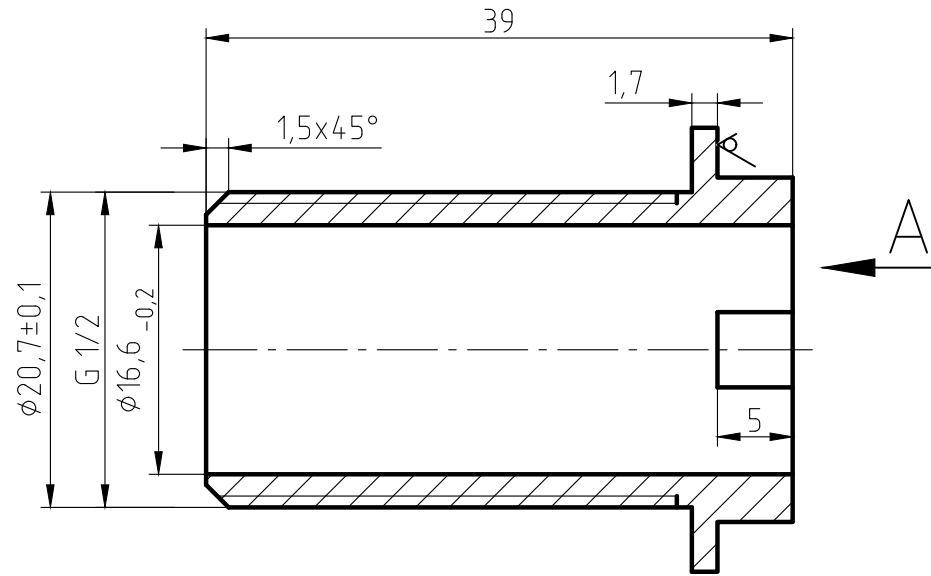

1. The parts should be 59-1 materials, no fissures surface sand-throwing treatment and nickel plating. All nickel plating.
2. Not specified R0.5, slope of 1*.
3. The logo is cave/hollow, depth is 0,3-0,5 mm.
4. Surface is clear and smoothly, deburring C0.2.
5. The dimentions on the drawings are of the finished products.
6. The Male thread should be bitten.

Изм.	Лист	№ докум.	Подп.	Дата	Ввертыш в дючку 1/2" ИС.071263-1			Лист	Масса	Масштаб
Разраб.									39,3	2:1
Пров.								Лист	Листов	1
Т.контр.										
Н.контр.										
Утв.										