

Перв. примен.

Справ. №

Подп. и дата

Инв. № дубл.

Взам. инв. №

Подп. и дата

Инв. № подл.

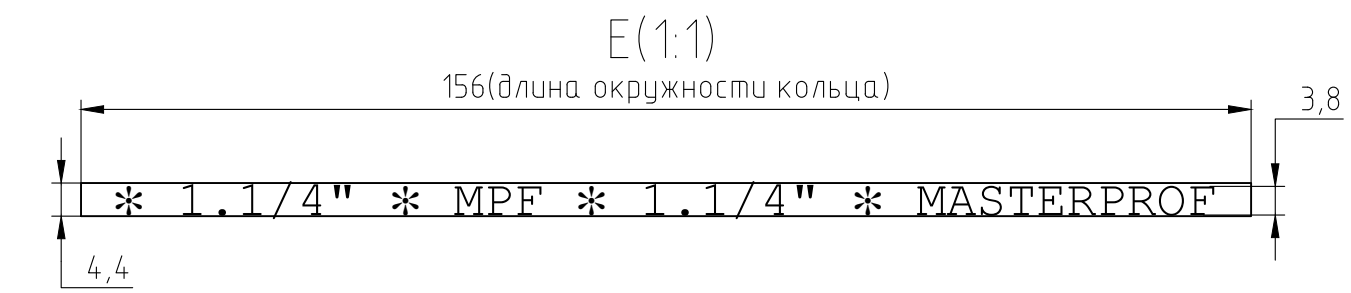
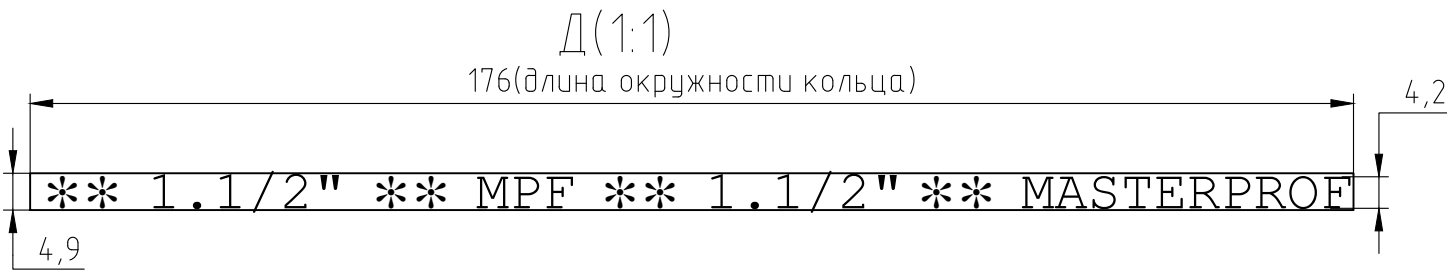
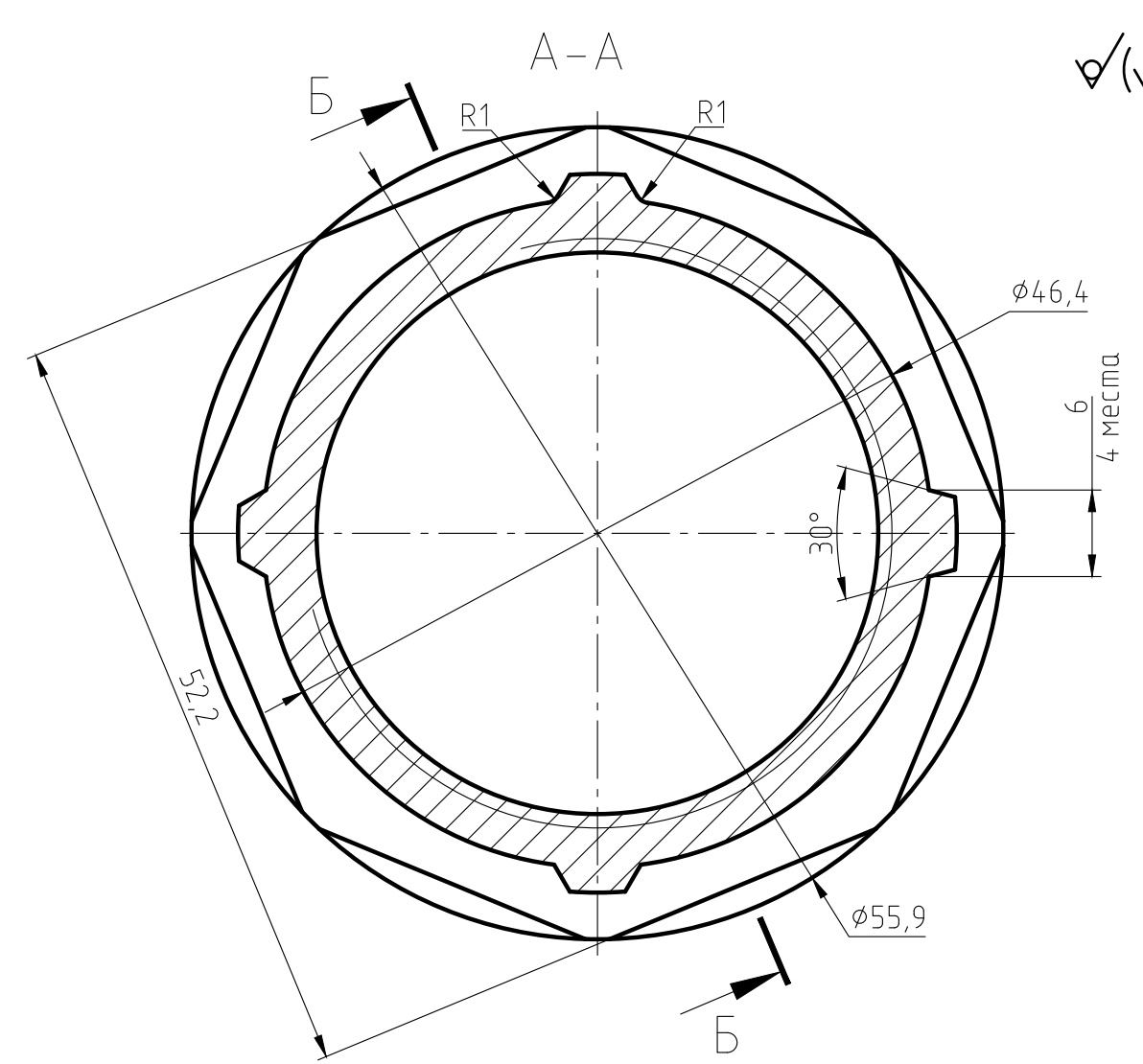
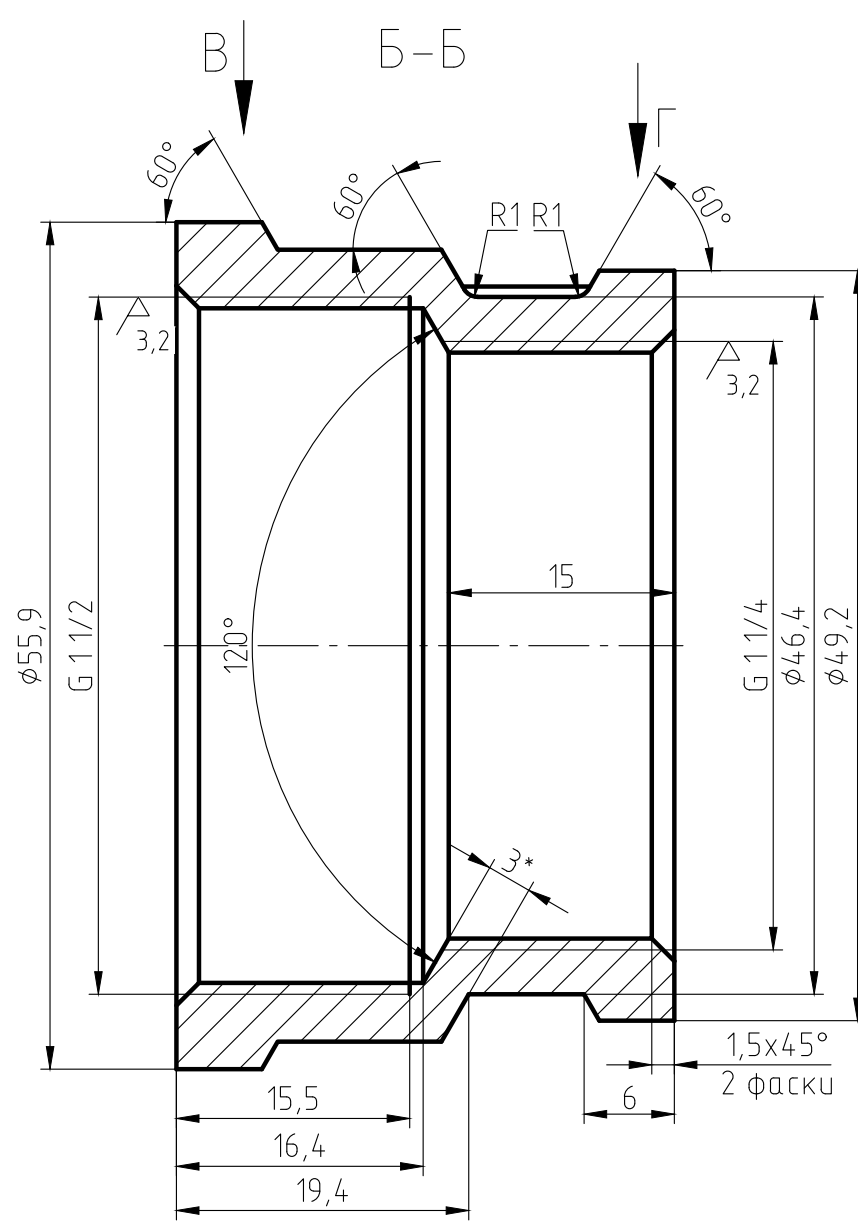
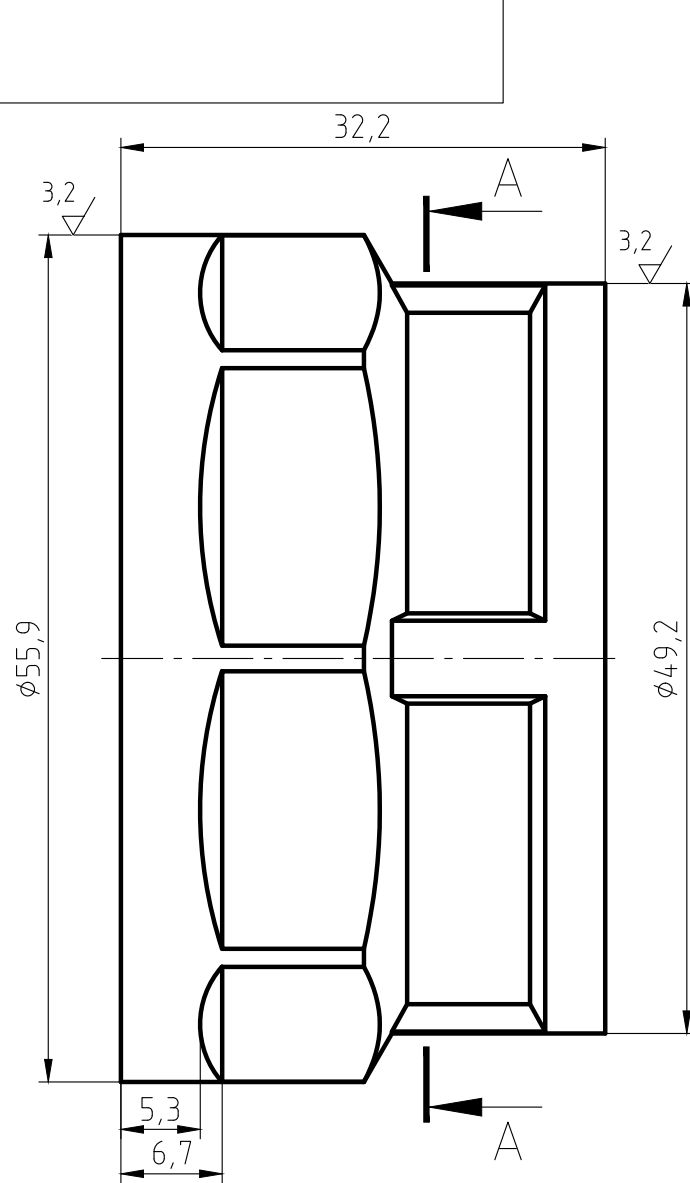

1. The parts should be 59-1 materials, no fissures surface sand-throwing treatment and nickel plating. All nickel plating.
2. Not specified R0.5, slope of 1*.
3. The logo is cave/hollow. depth is 0.3-0.5 mm.
4. Surface is clear and smoothly, deburring C0.2.
5. The dимensions on the drawings are of the finished products.
6. The Male thread should be bitten.

Изм.	Лист	№ докум.	Подп.	Дата	Муфта переходная 1 1/4"x1 1/2" ВВ ИС.071997	Лист	Масса	Масштаб
Разраб.							165,9	2:1
Пров.						Лист	Листов	1
Т.контр.								
Н.контр.					ЛС 59-1ГОСТ 15527-2004			
Утв.								