

√ Ra 3,2 (√)

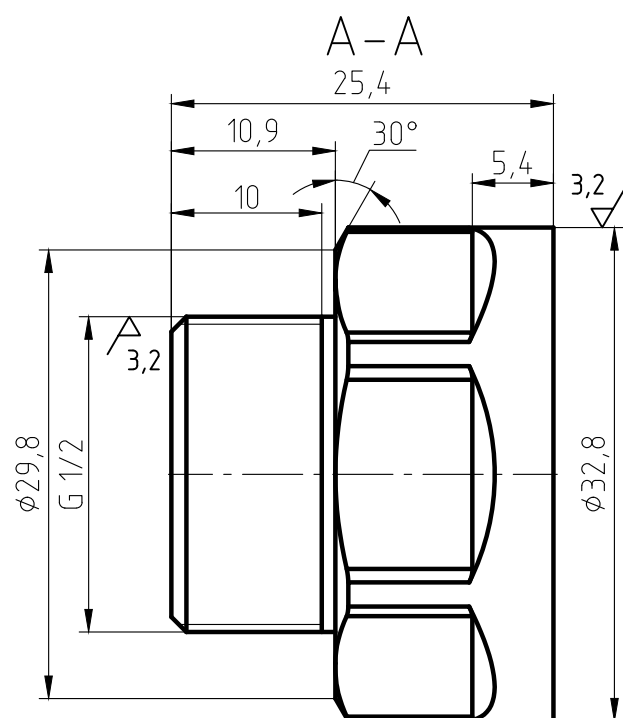
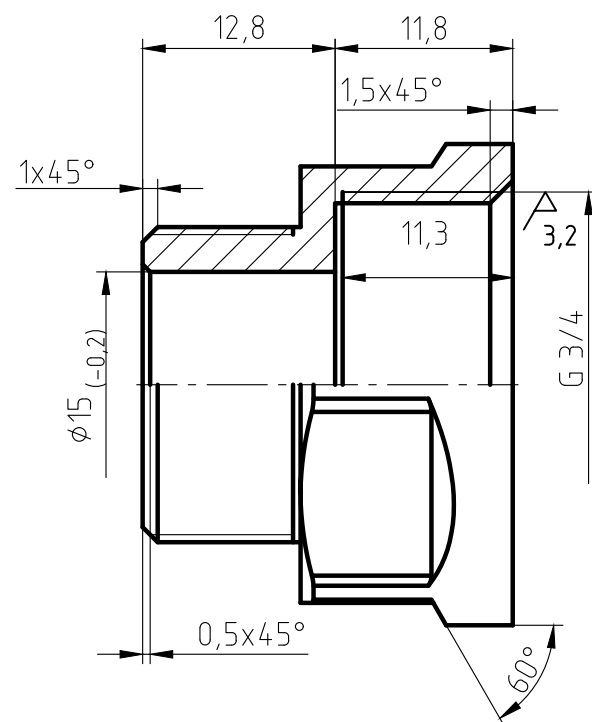
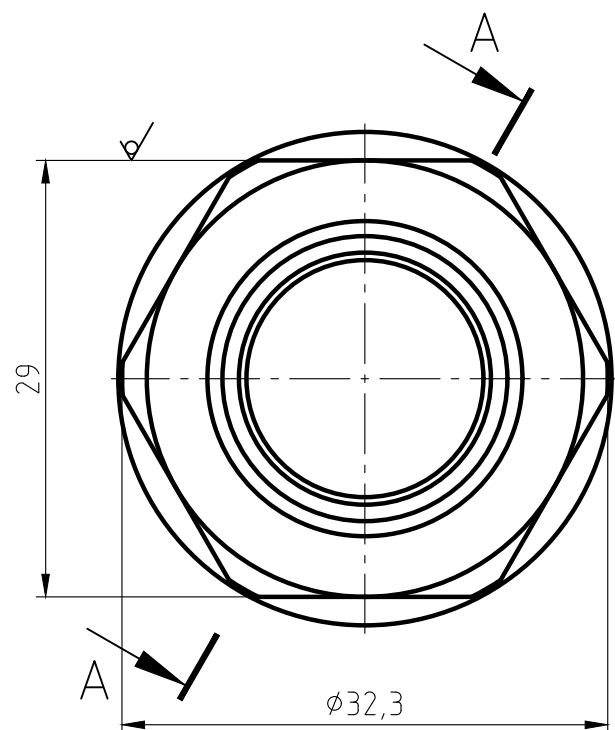

1. The parts should be 59-1 materials, no fissures surface sand-throwing treatment and nickel plating. All nickel plating.
2. Not specified R0.5, slope of 1*.
3. The logo is cave/hollow. depth is 0.3-0.5 mm.
4. Surface is clear and smoothly, deburring C0.2.
5. The dimintions on the drawings are of the finished products.
6. The Male thread should be bitten.

Перв. примен.
Справ. №

Подп. и дата
Инв. № дубл.
Взам. инв. №
Подп. и дата
Инв. № подл.

					Переходник с ребордой 1/2"x3/4" ИС.072032	Лист	Масса	Масштаб
Изм.	Лист	№ докум.	Подп.	Дата			52,9	2:1
Разраб.					Лист		Листов	1
Пров.					ЛС 59-1 ГОСТ 15527-2004			
Т.контр.								
Н.контр.								
Утв.								