

3 2 / (✓)

Перв. примен.
Справ. №
Подп. и дата
Инв. № дудл.
Взам. инв. №
Подп. и дата
Инв. № подл.

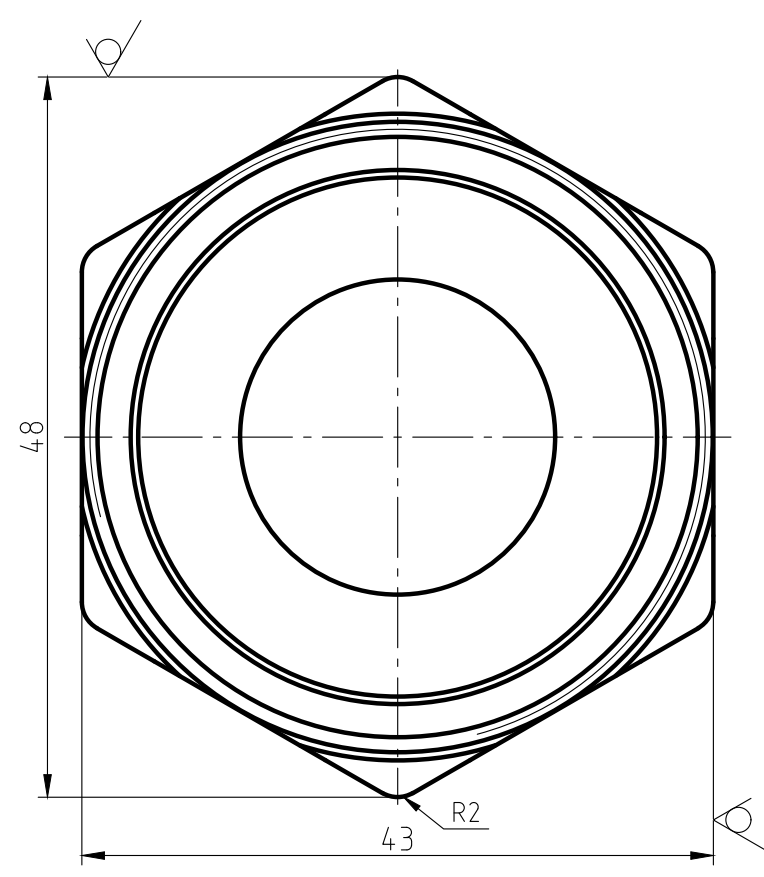
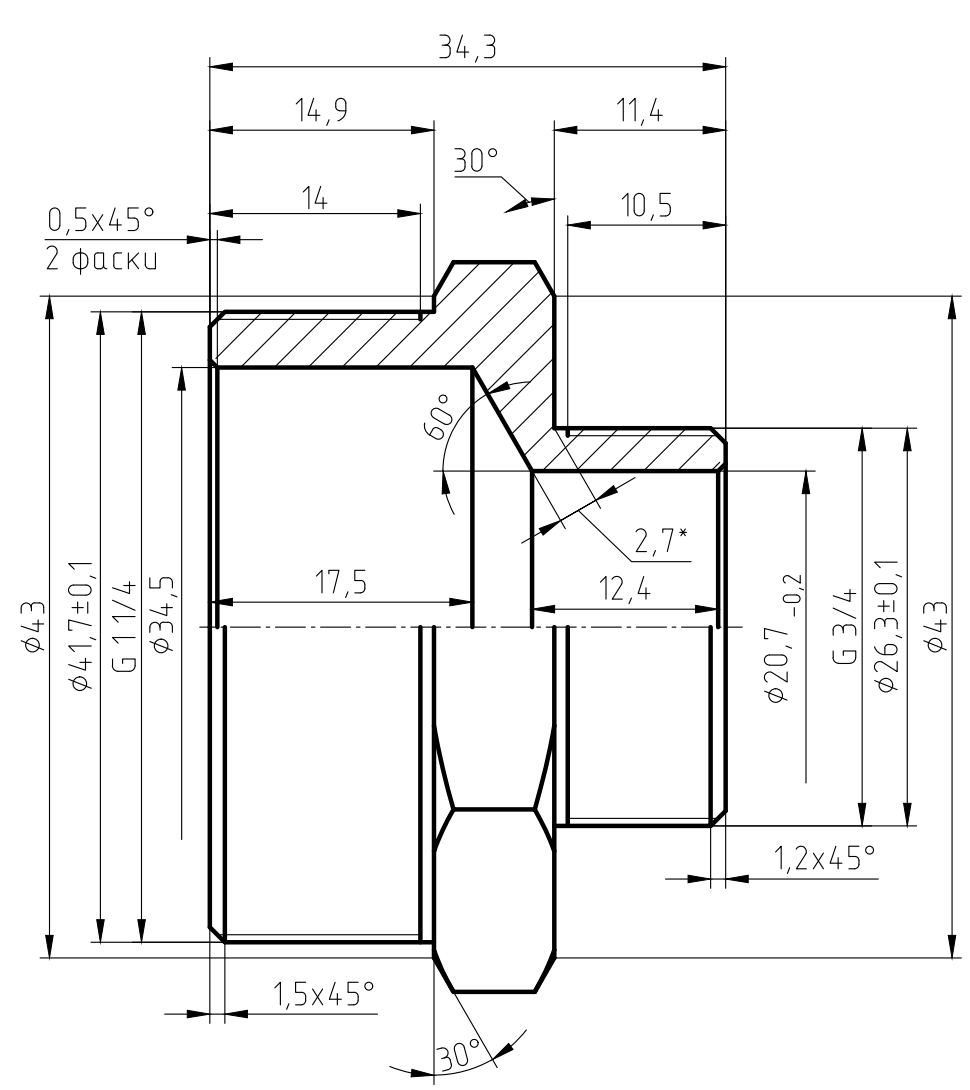

1. The parts should be 59-1 materials, no fissures surface sand-throwing treatment and nickel plating. All nickel plating.
2. Not specified R0.5, slope of 1*.
3. Surface is clear and smoothly, deburring C0.2.
4. The dimentions on the drawings are of the finished products.
5. The Male thread should be bitten.

Изм.	Лист	№ докум.	Подп.	Дата	Ниппель переходник 3/4"-1 1/4" НН ИС.072018	Лист	Масса	Масштаб
Разраб.							120,9	2:1
Пров.						Лист	Листов	1
Т.контр.								
Н.контр.								
Утв.					ЛС 59-1 ГОСТ 15527-2004			