

3,2  
▽(√)

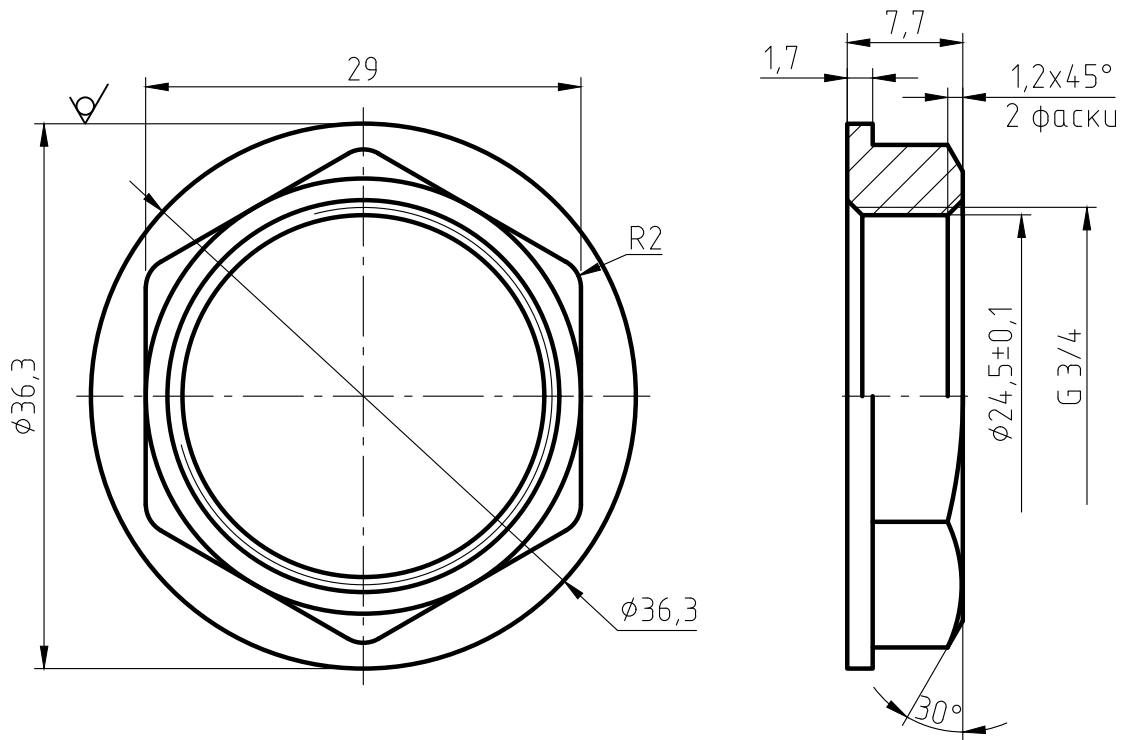

1. The parts should be 59-1 materials, no fissuress surface sand-throwing treatment and nickel plating.
2. Not specified R0.5, slope of 1\*.
3. The logo is cave/hollow. depth is 0.3-0.5 mm.
4. Surface is clear and smoothly, deburring C0.2.
5. The dimitions on the drawings are of the finished products.
6. The Male thread should be bitten.

Перв. примен.

Справ. №

Подп. и дата

Инв. № дубл.

Взам. инв. №

Подп. и дата

Инв. № подл.

Изм.	Лист	№ докум.	Подп.	Дата
Разраб.				
Пров.				
Т.контр.				
Н.контр.				
Утв.				

Контрзаїка с  
редордої 3/4"  
ИС.070897

Лист	Масса	Масштаб
	18,7	2:1
Лист	Листов	1