

3,2/√(√)

Перв. примен.

Справ. №

Подп. и дата

Инв. № дубл.

Взам. инв. №

Подп. и дата

Инв. № подл.

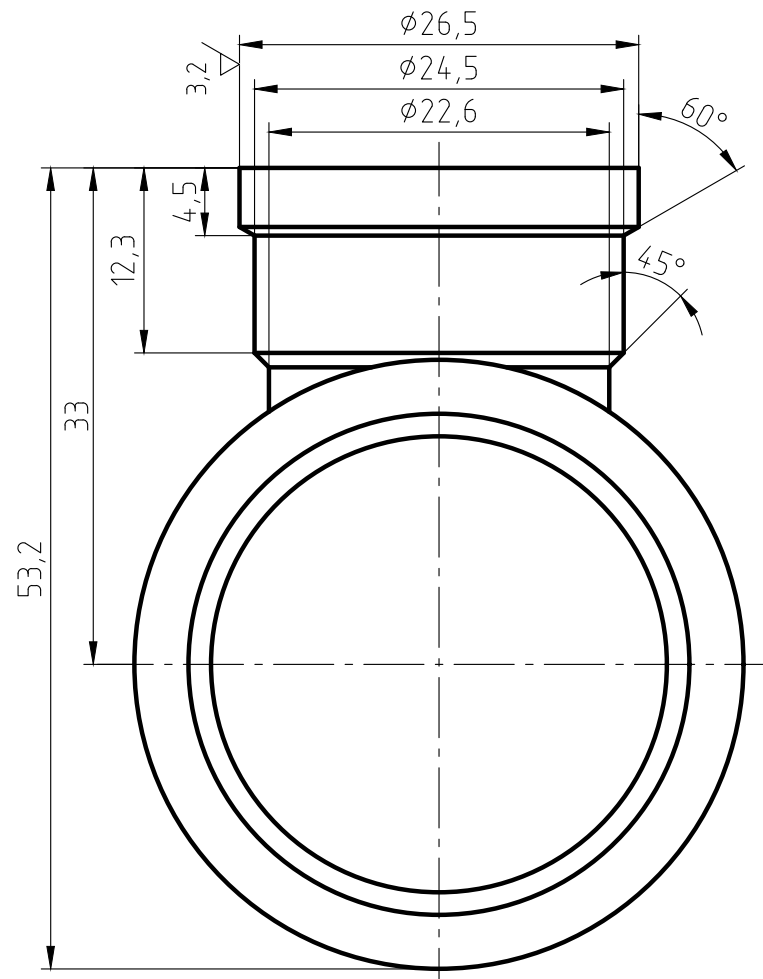
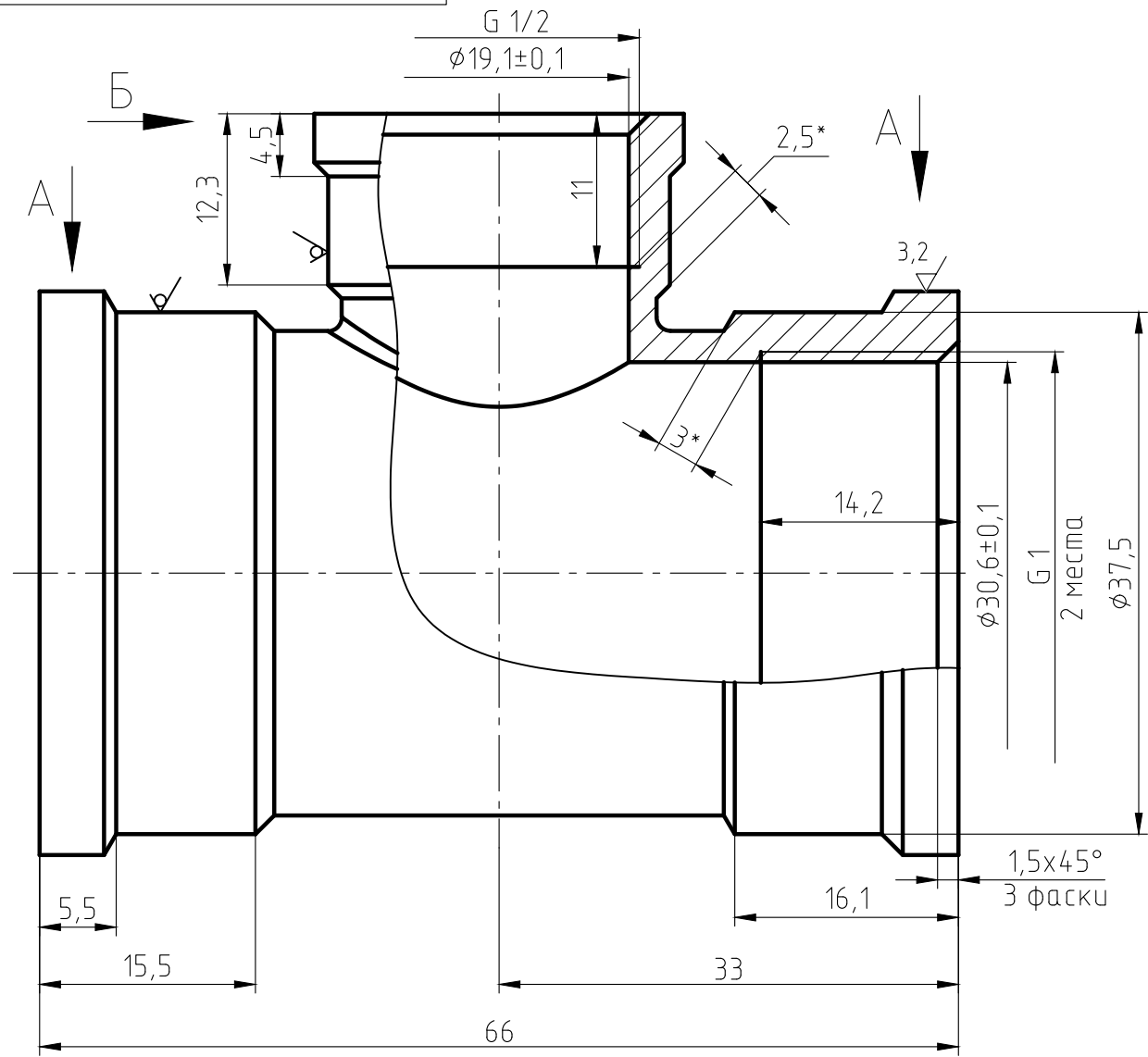

Б(1:1)
83(длина окружности кольца)
* 1/2" * MPF * 1/2" * MASTERPROF

А(1:1)
127(длина окружности кольца)
*** 1" *** MPF *** 1" *** MASTERPROF

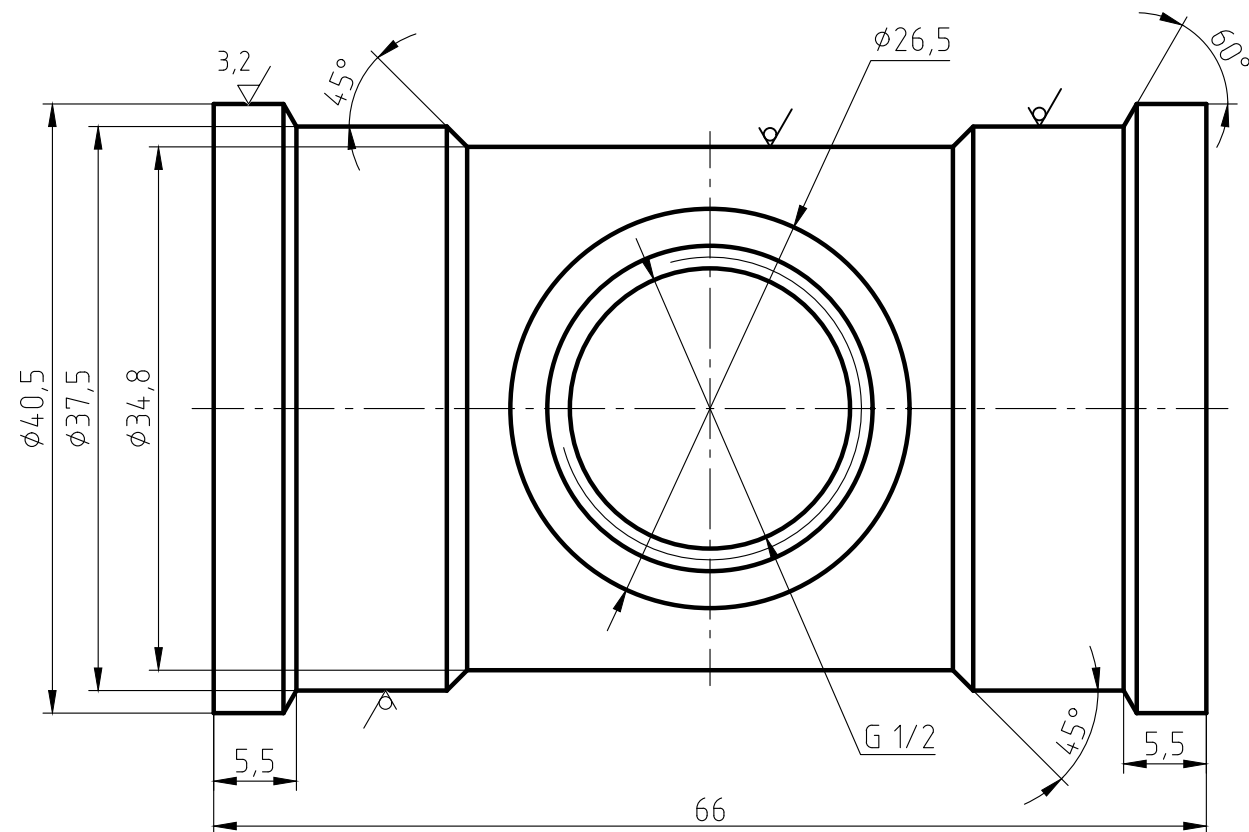

1. The parts should be 59-1 materials, no fissures surface sand-throwing treatment and nickel plating. All nickel plating.
2. Not specified R0.5, slope of 1*.
3. The logo is cave/hollow, depth is 0,3-0,5 mm.
4. Surface is clear and smoothly, deburring C0.2.
5. The dimentions on the drawings are of the finished products.
6. The Male thread should be bitten.

Изм.	Лист	№ докум.	Подп.	Дата	Тройник 1"-1/2"-1" ВВВ ИС.072076	Лист	Масса	Масштаб
Разраб.							181	2:1
Пров.						Лист	Листов	
Т.контр.								
Н.контр.					ЛС 59-1ГОСТ 15527-2004			
Утв.								