

3,2
 $\sqrt{\text{V}}$ (\checkmark)

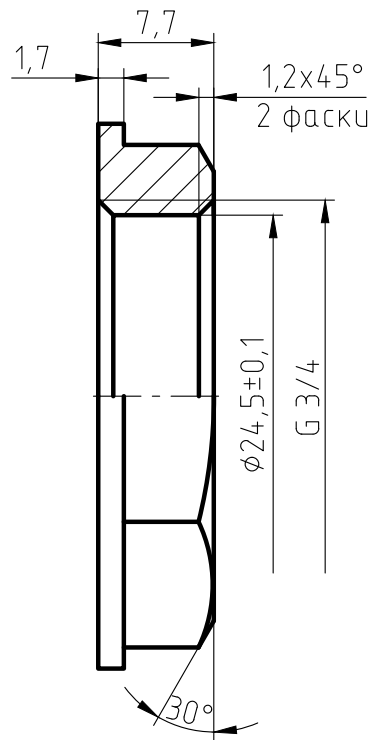
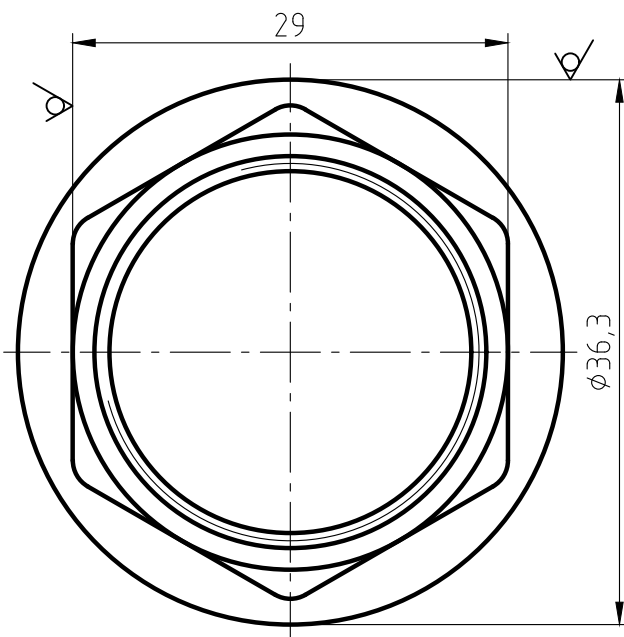

1. The parts should be 59-1 materials, no fissuress surface sand-throwing treatment and nickel plating. All nickel plating.
2. Not specified R0.5, slope of 1*.
3. The logo is cave/hollow, depth is 0,3-0,5 mm.
4. Surface is clear and smoothly, deburring C0.2.
5. The dимentions on the drawings are of the finished products.
6. The Male thread should be bitten.

Перв. примен.				
Справ. №				
Подп. и дата	Инв. № дубл.	Взам. инв. №	Подп. и дата	
Инв. № подл.	Разраб.	Пров.	Т.контр.	Н.контр.
	Утв.			
		Контрагайка с ребордой 3/4" ИС.071264-2		
		Лит.	Масса	Масштаб
			17,7	2:1
		Лист	Листов	1