

Перв. примен.

Справ. №

Подп. и дата

Инв. № дубл.

Взам. инв. №

Подп. и дата

Инв. № подл.

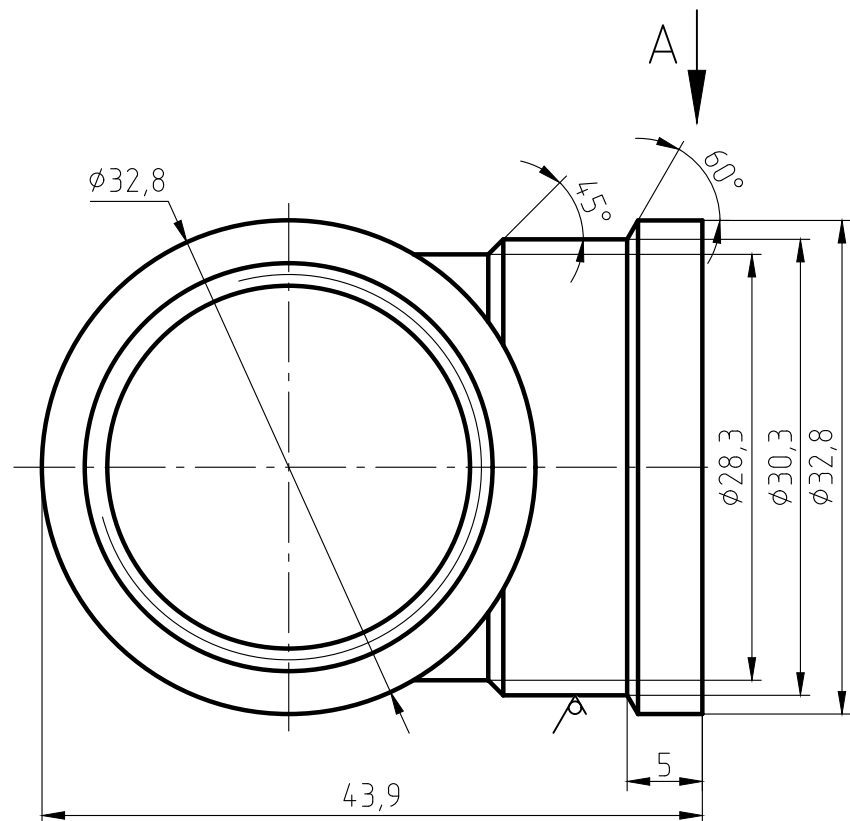
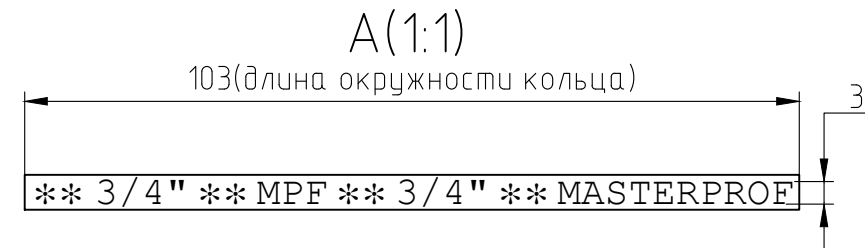
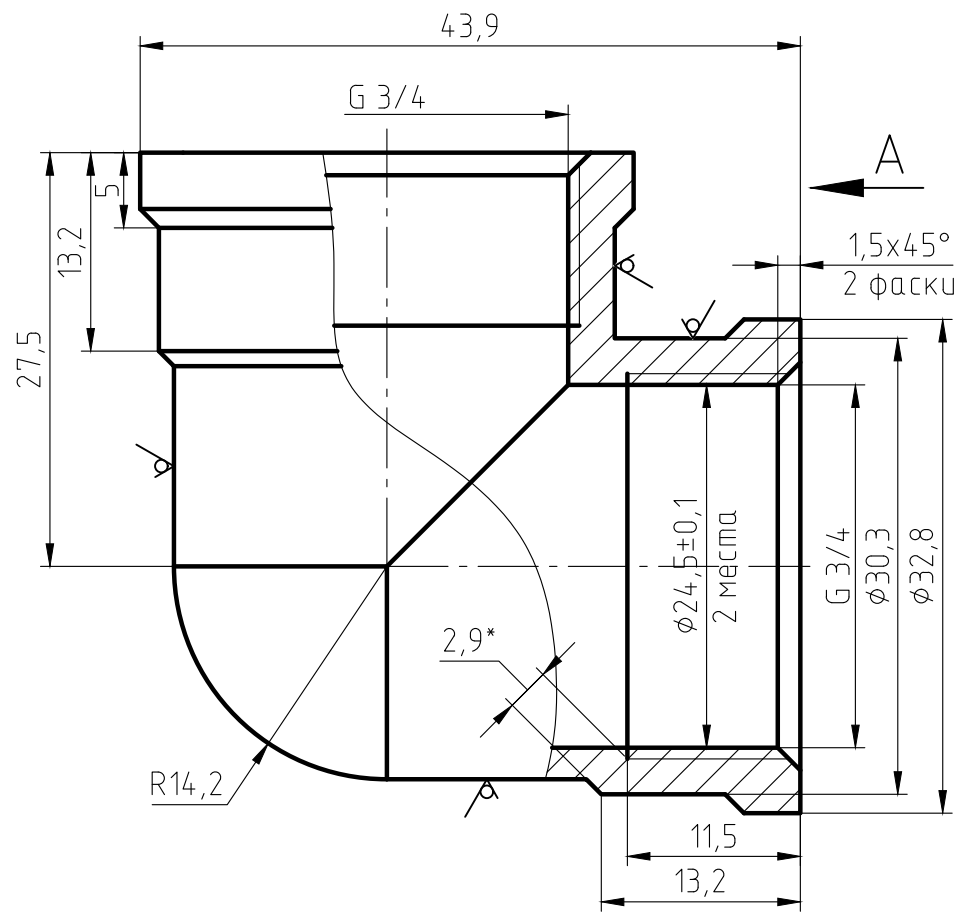

1. The parts should be 59-1 materials, no fissures surface sand-throwing treatment and nickel plating. All nickel plating.
2. Not specified R0.5, slope of 1°.
3. The logo is cave/hollow, depth is 0,3-0,5 mm.
4. Surface is clear and smoothly, deburring C0.2.
5. The dимensions on the drawings are of the finished products.
6. The Male thread should be bitten.

Изм.	Лист	№ докум.	Подп.	Дата	Угольник 3/4" ВВ ИС.072081			Лист	Масса	Масштаб
Разраб.								95,4	2:1	
Пров.							Лист	Листов		
Т.контр.										
Н.контр.					ЛС 59-1 ГОСТ 15527-2004					
Утв.										